

SumiDrill WDX型

SumiDrill WDX Type 第15版

安定感、極まる。

Excellent Stability

New

CVD材種 ACP100を
シリーズ化! CVD grade ACP100 Expansion.

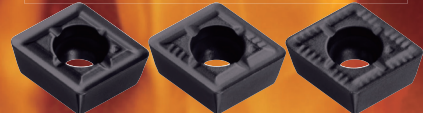

鋼・鋳鉄の高速加工に!
Suitable for high speed machining of steel and cast iron.



バランス設計で安定した高品位穴あけを実現

Balanced design for stable and high-quality drilling

3種類のチップブレーカで切りくず問題解消

4つの材種で、鋼からステンレス鋼・鋳鉄・非鉄金属加工に対応
新コーティング技術で耐摩耗性・耐欠損性を向上し長寿命化を実現
中心刃・外周刃兼用チップの4コーナー使いで経済的

Three types of chipbreaker to solve chip control problems
4 grades suitable for machining various metals, such as steel, stainless steel, cast iron and non-ferrous metals
New coating technology has improved wear and fracture resistance and achieved longer tool life
Economical as the four corners of the central and periferal inserts can be used



サイズ Sizes	2D	: ø13.0 ~ 68.0mm	4D	: ø13.0 ~ 63.0mm
	3D	: ø13.0 ~ 68.0mm	5D	: ø13.0 ~ 55.0mm

刃先交換ドリル SumiDrill® Indexable Insert Drills WDX型 SumiDrill WDX Type



■特長

SumiDrill WDX型は、優れた切削バランスにより、一般鋼からステンレス鋼まで、被削材を問わず安定した穴あけ加工が可能です。また、独創的な3種類のチップブレーカを採用し、切りくず処理の向上と切削抵抗の低減を実現することにより、剛性の低い加工状況でも安心して使用することができます。

Characteristics

SumiDrill WDX Type provides so excellent cutting balance that it enables stable drilling on a wide range of work materials from general steel to stainless steel.

●シリーズ構成 Series

(単位:mm)

加工穴深さ Drilling Depth	在庫サイズ Available drill diameter in stock
2D用 2D	φ13.0~φ68.0
3D用 3D	φ13.0~φ68.0
4D用 4D	φ13.0~φ63.0
5D用 5D	φ13.0~φ55.0

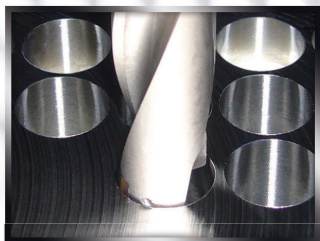

バランス設計で高品位穴あけ
Balanced design for high-quality drilling

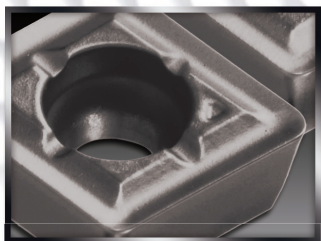

ACP100/ACP300/ACK300/DL1500を採用
Adopted ACP100, ACP300, ACK300 and DL1500

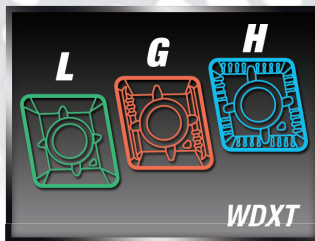

3種類のブレーカで多用途に対応
3 types of chipbreakers to support numerous applications

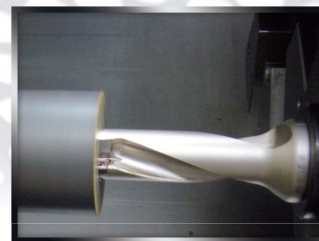

旋盤での加工にも対応
Suitable for use on a lathe

多彩な加工をこなす多機能工具 Versatile Tool to Perform a Variety of Machining Applications



ボディに特殊硬化表面処理を施し耐久性を高めたことにより、通常の穴あけ加工だけでなく、穴広げや座ぐり加工など多彩な加工用途で長時間安定して使用可能。

Special surface hardening treatment has been applied to improve durability, allowing stable and long-term use for a variety of machining applications, such as hole widening and spot facing as well as ordinary drilling.

■多彩な加工に対応 Suitable for Machining Diverse Shapes and Angles

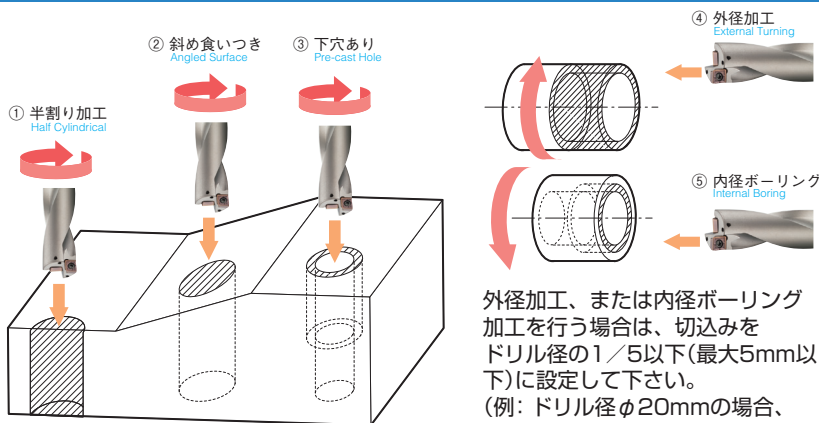

For machining external or internal diameter, the setting of the cut depth shall be 1/5 or less of the drill diameter (Max. 5mm or less). (Ex: If the drill diameter is φ20mm, the cut depth shall be 4mm or less).

■平坦に近い底面形状 Almost-flat Bottom Profiles

底面形状が平坦に近い為、後工程での仕上げがラク!
Easy finishing because of very flat hole bottom

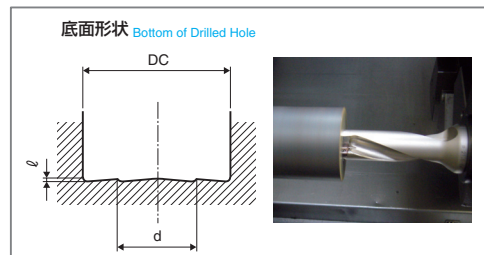

●底面形状寸法 Dimensions of hole bottom (単位:mm)

ドリル径 DC Drill Diameter	d	ℓ (最大段差) ℓ (Max. Step)
φ13.0~φ18.0	DC / 2	0.4
φ18.5~φ28.5	DC / 2	0.6
φ29.0~φ36.0	DC / 2	0.8
φ37.0~φ55.0	DC / 2	1.2
φ56.0~φ68.0	DC / 2	1.2

ダントツの
Superbly

バランス設計を実現！

Balanced Design

▶ 中心刃の切削抵抗 ≒ 外周刃の切削抵抗 ◀

Cutting resistance of the central insert is approximately equal to that of the peripheral insert

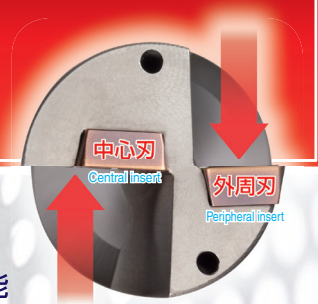

■ バランス設計とは… Balanced design means that:

加工時の切削抵抗が中心刃と外周刃でバランスするように配置し、
更に相互の位置関係を最適化することで、安定した穴あけ加工が可能

Cutting resistance during machining is balanced between central and peripheral inserts, and the relative position of each insert is optimised to provide stable drilling.

水平分力値の比較

Comparison of Horizontal Component Values

食い付き部と貫通穴出口においてもバランスが保たれ、安定加工が可能。

Cutting resistance is kept balanced at the initial engagement and at the exit point of the hole, so drilling performance is stable.

SumiDrill WDX 型 SumiDrill WDX Type

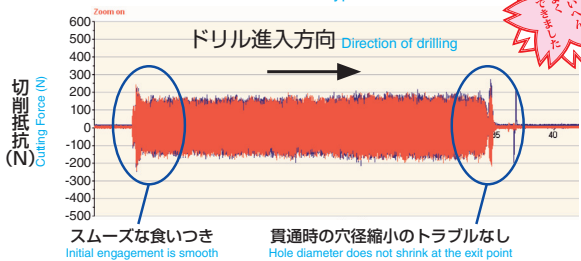

従来品及び他社品 Conventional and Competitor's Products

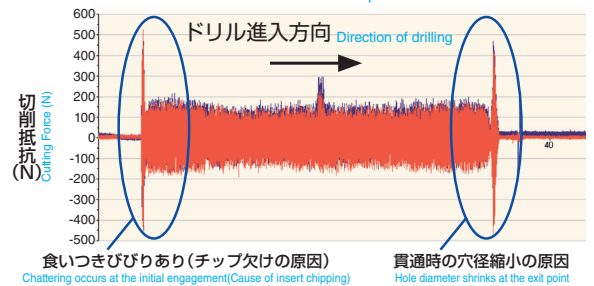

高品質の穴あけ
High-quality Drilling

バランス設計で、安定かつ高精度の穴あけ加工を実現し、面粗度も良好

Balanced design enables stable and precise drilling and creates good surface roughness

加工穴径の精度比較 Accuracy Comparison of Drilled Holes

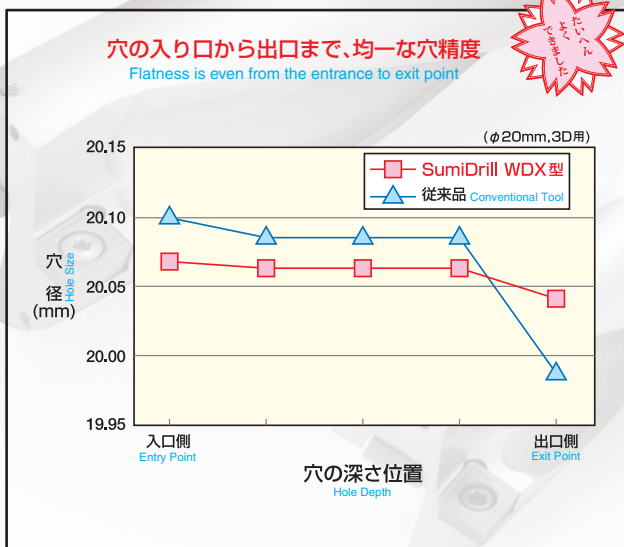

加工穴面粗さ比較 Comparison of Surface Roughness of Drilled Holes

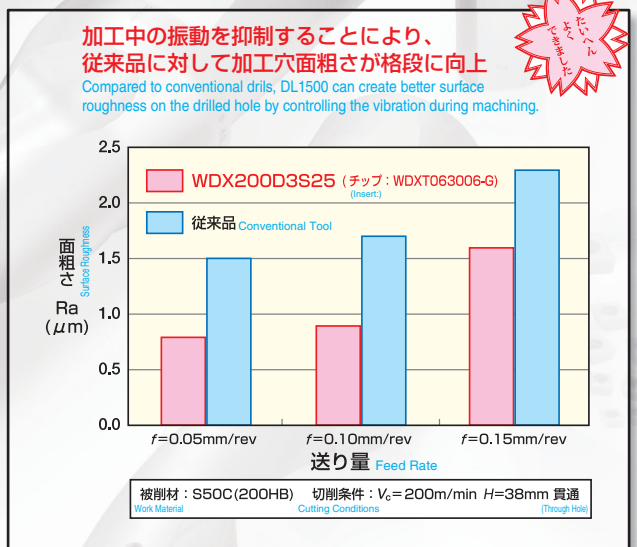

SumiDrill WDX型

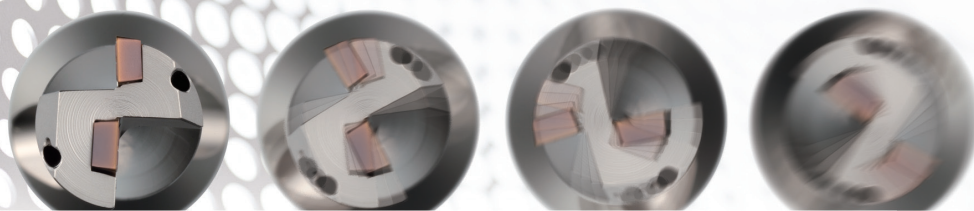

深穴加工用に5Dタイプが登場! (サイズ: $\phi 13.0\text{mm} \sim \phi 55.0\text{mm}$) 5D Type for Deep Holes (Sizes: $\phi 13.0\text{ mm to } \phi 55.0\text{ mm}$)

■ 特長 Characteristics

SumiDrill WDX型 5D用は、専用溝形状+クーラント穴サイズUPで、深穴加工においても、良好な切りくず排出性能を実現しました。
SumiDrill WDX Type for 5D has a special groove shape and large coolant hole, allowing excellent chip evacuation during deep hole drilling.

大きなクーラント穴 Large coolant hole



クーラント案内溝 Groove of coolant guide

L/D=5 専用溝形状 Special groove shape for L/D=5



■ 性能 Performance

ホルダの特長 Characteristics	断面形状 Cross Section	切削抵抗 Cutting Resistance	加工面 (出口) Machined Surface (Exit)
WDX260D5S32 L/D=5の専用溝形状 Special groove shape of L/D=5 ※ 切りくず排出重視設計 溝容量を大きくとった設計で切りくず排出性を向上させ、L/D=5の穴あけにおいても、安定加工が可能。 ※ Groove shape is focused on smooth chip evacuation. SumiDrill WDX Type has large grooves for metal chip evacuation. It also enables stable drilling of L/D=5 holes.		(N) 12,000 10,000 8,000 6,000 4,000 2,000 0 -2,000 -4,000 スラスト衝量はL/D=4溝設計より大きいですが、L/D=5の深穴加工でも、安定加工可能 Amplitude in the thrust direction is larger than that of drill with grooves up to L/D=4, but drilling performance of deep holes L/D=5 is stable. スラスト Thrust 水平分力 Normal Component 加工深さ L/D=4 加工深さ L/D=5	穴奥まで良好な加工面 Good machined surface from top to down of the hole
比較用工具 L/D=4の溝形状 Groove shape of L/D=4 ※ ドリル本体剛性重視設計 ドリル本体の剛性を上げる溝設計で、L/D=4までの浅穴加工で、安定加工が可能。 ※ Flute design is focused on greater rigidity of the drill. Therefore, it provides stable drilling for shallow holes of up to L/D=4.		(N) 12,000 10,000 8,000 6,000 4,000 2,000 0 -2,000 -4,000 穴奥で切りくず詰まり発生 Chip blockage at bottom of hole 但し、L/D=4までは安定加工可能 However, L/D=4 is stable. 刃先部が急激に劣化する Rapidly deteriorating cutting edge 加工深さ L/D=4 加工深さ L/D=5	穴奥で切りくず詰まりにより加工面悪化 (L/D=5付近) Four machined surface due to chip blockage at bottom of hole (near L/D=5)

被削材 Work Material : SUS304 チップ Insert : WDXTO73506-G
 切削条件 Cutting Conditions : $v_c=150\text{m/min}$ $f=0.05\text{mm/rev}$ $H=130\text{mm}$ (貫通穴 Through hole) Wet

他社品 Competitor's Product

SumiDrill WDX型

加工面、加工穴径共に良好!
Excellent finish of machined surface and hole

穴径 [mm] Hole Size

入口 Entrance 奥 Base 入口 Entrance 奥 Base

被削材 Work material : 機械部品 Machine component (SCM415)
 使用工具 Tool : WDX200D5S25
 チップ Insert : WDXTO63006-G (ACP300)
 切削条件 Cutting conditions : $v_c=185\text{m/min}$ $f=0.12\text{mm/rev}$ $H=87\text{mm}$ 貫通 Through hole Wet

- 加工面良好!! Good machined surface.
- 加工穴径の安定!! Size of hole diameter is stable

SumiDrill WDX型

正常摩耗 Normal wear

他社品 Competitor's Product

コーナー欠け すぐい面摩耗 Corner chipping, rake face wear

被削材 Work material : トラックリンク Tractor links (35MnBM)
 使用工具 Tool : WDX205D5D25
 チップ Insert : WDXTO63006-G (ACP300)
 切削条件 Cutting conditions : $v_c=100\text{m/min}$ $f=0.11\text{mm/rev}$ $H=60\text{mm}$ 貫通 Through Wet

- L/D=5においても安定加工を実現!!
- チップ欠け、摩耗が抑制され、寿命が安定!!
- Stable drilling even at L/D=5.
- Insert chipping and wear have been reduced and tool life has been stabilized.

SumiDrill WDX型

正常摩耗 Normal wear

他社品 Competitor's Product

コーナー欠け Corner chipping

被削材 Work material : 風力発電向けベアリング Bearing for wind power generation (42CrMo)
 使用工具 Tool : WDX330D5D40
 チップ Insert : WDXTO94008-L (ACP300)
 切削条件 Cutting conditions : $v_c=146\text{m/min}$ $f=0.10\text{mm/rev}$ $H=158\text{mm}$ 貫通 Through Wet

- チップ欠けによるワーク不良トラブル解消!!
- There are fewer defective workpieces caused by insert chipping.



耐摩耗性に優れたCVD材種ACP100^{New}で高速加工での長寿命化を実現!
Excellent wear resistance and longer tool life in high speed cutting have been achieved by ACP100

新コーティング技術「スーパーFFコート」により優れた耐摩耗性を示しながら、他材種と同様に中心刃に適用可能なため、外周刃と中心刃でチップを使い分ける必要なく、全4コーナを効率的に使用可能。

Not only do WDX T Series inserts offer superior wear resistance thanks to the new Super FF Coat coating technology, they can also be used as central inserts just like other grades, so there is no need to differentiate between peripheral and central inserts, and all four corners can be used efficiently.

■コーティングの特長 Feature of coating

▼ **スーパーFFコート (CVD: 化学蒸着法 (Chemical Vapor Deposition))** **ACP100**
Super FF Coat

膜の特長 Characteristics of Coating Layer

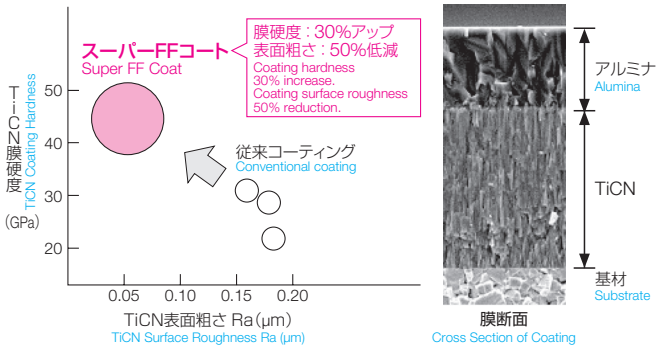

当社独自の CVD プロセス「スーパーFFコート」技術による結晶粒子の超微細化と、コーティング膜中応力制御技術により、優れた耐摩耗性と高い信頼性を両立

Our unique new CVD process, Super FF Coat technology, produces ultra-flat boundary faces between coating layers and super ultra-fine coating particles to achieve higher reliability and longer tool life.

▲ **NEWスーパーZXコート/スーパーZXコート (PVD: 物理蒸着法 (Physical Vapor Deposition))** **ACP300** **ACK300**
NEW Super ZX Coat / Super ZX Coat

膜の特長 Characteristics of Coating Layer

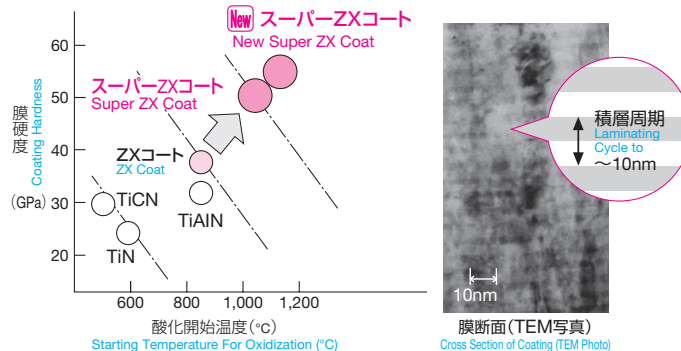

当社独自の薄膜コーティング技術と先進のナノテクノロジーを駆使し、一層の厚みがナノメートル台(1ナノメートルは10億分の1メートル)の超薄膜を交互に数千層積層させた超多層膜「NewスーパーZXコート」を採用

Utilising our proprietary thin layer coating technology and advanced nanotechnology, Sumitomo Electric Hardmetal has developed NEW Super ZX Coat and Super ZX Coat, coatings that consist of approximately 1,000 alternating, nanometre-level-thin (1 nanometre = 1 billionth of a metre) layers.

非鉄金属加工用材種オーロラコート DL1500
Aurora coating material for machining non-ferrous metal DL1500

非鉄金属加工用新材種DL1500は従来品に対し、耐溶着性が格段に向上しました。アルミニウム合金はもちろん、銅合金などの穴あけ加工に最適です。

Compared to previous materials, DL1500 provides superior adhesion resistance. Therefore, it is ideal for drilling holes on copper alloy as well as aluminum alloy.

■使用実例 Application Examples

		DL1500	ACK300
外周刃 Peripheral Insert	すくい面 Rake Face		
	逃げ面 Flank		
中心刃 Central Insert	すくい面 Rake Face		
	逃げ面 Flank		

被削材 : ADC52
Work Material:
使用工具 : WDX250D3S25 (DL1500,G型)
Tool:
切削条件 : $v_c=150\text{m/min}$ ($n=1,911\text{min}^{-1}$)
Cutting Conditions: $f=0.1\text{mm/rev}$
 $H=50\text{mm}$ (貫通穴 Through hole) Wet

※溶着 : Adhesion

(L型/G型/H型)
(L Type/G Type/H Type)



3種類のブレーカで、幅広い被削材、用途に対応

Three types of chipbreakers to support a wide range of work materials and applications

ブレーカ中央部に形成された「切りくず制御溝」の効果により切りくず流出方向の制御を可能にし、3種類の用途別ブレーカを使い分けることでさまざまな被削材、条件下において、切りくずトラブルを激減
"Chip controlling groove" created in the center part of the breaker controls the direction of chip evacuation. Chip problems with different work materials under various conditions can be reduced drastically by using these three chip breakers selectively depending on the usage.

■ブレーカの種類 Chipbreaker Types

L型 低速送り・切りくず処理用
Low feed, chip management type

断面形状
Cross Section

G型 汎用
General Purpose

断面形状
Cross Section

H型 刃先強化型
Strong Edge Type

断面形状
Cross Section

●すくい角 Rake Angle



●ブレーカ幅 Chipbreaker Width



■4コーナー使いチップで経済的 Economical by the use of four corners

中心刃、外周刃兼用チップ採用で、中心刃2コーナー、外周刃2コーナーの計4コーナーが使用可能

Inserts have four cutting edges in total: two central cutting edges and peripheral cutting edges.

CVDコーティング材種であるACP100も対応！
ACP100, CVD coated grade is adopted.

※中心刃：Central cutting edge
外周刃：Peripheral cutting edge

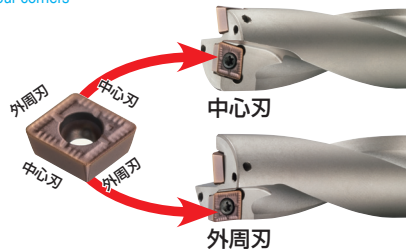

チップ選択ガイド — いろいろ選べるWDX用チップシリーズ

Insert Selection — WDX Type Insert Series Offers Wide Selection

4 種類の材種 Four material grades

被削材	ACP100	ACP300	ACK300	DL1500
P 鋳 (高速加工用) Cast (High Speed Machining)	○			
P 鋳 (一般加工用) Cast (General Machining)		○		
M ステンレス鋼 Stainless Steel		○		
K 鋳鉄 (高速加工用) Cast Iron (High Speed Machining)	○			
K 鋳鉄 (一般加工用) Cast Iron (General Machining)			○	
N 非鉄金属 Non-Ferrous Metal				○

3 種類のブレーカ Three types of chip breakers

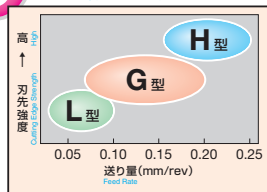

10 種類の組合せが可能に！ Ten possible combinations

ACP100	ACP300	ACK300	DL1500
P K L型	P M L型	P K L型	
P K G型	P M G型	P K G型	N G型
P K H型	P H型	K H型	

第2推奨
2nd Recommendation
P

P 鋼

低速送り・切りくず処理用
Low Feed, Chip Management Type

L型 ACP300

- SS400, SCM415, SCM420 等の加工に
For machining SS400, SCM415, SCM420, etc.
- 切りくず処理に問題がある場合は、高速低送りを推奨します
In case of chip control problem, high speed with low feed rate is recommended.
- 切りくず焼けにより振動が発生する場合は、送りを下げる
In case of vibration due to burnt chips, reduce the feed rate.

P 鋼

汎用
General Purpose

G型 ACP100

- 一般鋼・合金鋼の加工で、逃げ面摩耗発生が大きい場合に
For application where severe flank wear may be caused by machining general alloy or alloy steel

P 鋼

低速送り・切りくず処理用
Low Feed, Chip Management Type

L型 ACP100

- 送り条件が低い場合に
For low feed rate conditions

P 鋼

刃先強化型
Strong Edge Type

H型 ACP300

- 斜め食いつき等による断続（入口・貫通）加工の場合、送りは断続部で下げる（f0.05程度）
For interrupted machining (at entrance/exit) of angled surfaces, reduce the feed rate (to approximately f 0.05) at each interruption.
- 高硬度材（熱処理）の加工により、刃先強度不足の場合に
Ideal to use when the cutting edge is weakened due to machining hardened material (heat treatment)

P 鋼

切りくず処理改善
（低炭素鋼など）
Improvement of chip control
(low-carbon steel, etc.)

P 鋼

耐摩耗性不足
Lack of wear resistance

P 鋼

初期チッピング対応
（断続・高硬度など）
Reduction of initial chipping
(caused by interrupted machining, machining hard material, etc.)

第1推奨
1st Recommendation
P M
K N

汎用
General Purpose

G型

一般鋼・合金鋼 / ステンレス鋼加工用には
ACP300
For machining general steel, alloy steel or stainless steel

鋳鉄加工用には
ACK300
For machining cast iron

非鉄金属加工用には
DL1500
For machining non-ferrous metals

P 鋼 **M** ステンレス鋼
K 鋳鉄 **N** 非鉄金属

M ステンレス鋼

切りくず処理改善
Improvement of chip control

K 鋳鉄

耐摩耗性不足
（高速加工）
Lack of wear resistance
(High speed machining)

K 鋳鉄

初期チッピング対応
（断続・高送り）
Reduction of initial chipping
(interrupted/high feed rate machining, etc.)

第2推奨
2nd Recommendation
M K

M ステンレス鋼

低速送り・切りくず処理用
Low feed, chip management type

L型 ACP300

- 設備上、切削速度・送りが上げられず、切りくず処理が問題になる場合に
L Type ACP300 is ideal to solve chip evacuation problem caused by low cutting speed and low feed rate due to facility reasons.

K 鋳鉄

汎用
General Purpose

G型 ACP100

- 鋳鉄加工で逃げ面摩耗性が大きい場合に
For applications where severe flank wear may be caused by machining cast iron.
- 高速・低～中送りで摩耗を抑えたい場合に
Ideal for reducing wear at high speeds with low to medium feed rates.

K 鋳鉄

刃先強化型
Strong Edge Type

H型 ACK300

- 鋼加工同様に、斜め食いつき等による断続切削の場合に
Similar to steel machining, H Type ACK300 is ideal for interrupted machining on angled surfaces.
- 高送り加工により、刃先強度不足の場合に
With strong edges, it is ideal for machining workpieces at high feed rate.

* 200HB 以上の高硬度鋼加工及び鋼高速加工の場合、ACP100 が第1推奨となります。
* ACP100 is recommended the first in the cutting of high hardness steel (≥200HB) and the high speed cutting of steel.

SumiDrill WDX型 (2D用)

SumiDrill WDX Type

炭素鋼 合金鋼 ~0.28% C 0.23%~	調質鋼	高硬度鋼 ~45HRC 46HRC~	ステン レス鋼	Ti合金	耐熱鋼	鋳鉄	タタリ 鋼鉄	アルミ 合金	銅合金	複合材 CFRP
◎	◎	○	◎			◎	◎	◎		



加工公差の目安 Range of machining tolerance : -0.05 ~ +0.15

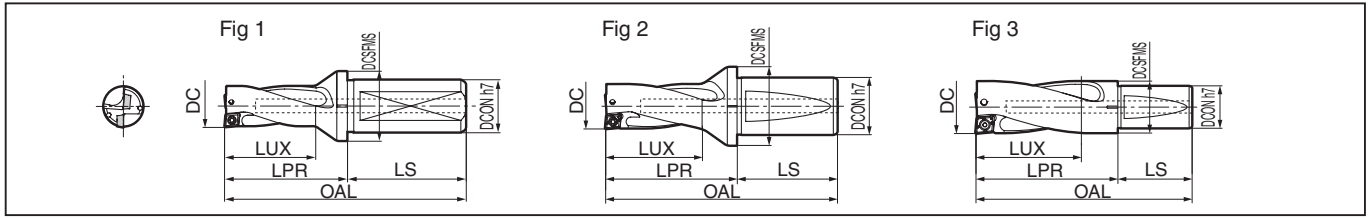

ホルダ刃径φ13.0~45.0mm

刃径 Diameter DC		在庫 Stock	型番 Cat. No.	首下長 Length LUX	突出長 Over hang LPR	全長 Length OAL	シャンク Shank LS	接続部 Diameter DCSFMS	径 Diameter DCON	半径方向 オフセット量 (最大) Offset	適用チップ Insert	Fig
13.0	●		WDX 130D2S20	29	44	88				0.35		
13.5	●		135D2S20	30	45	89				0.30		
14.0	●		140D2S20	31	46	90	44	28.0	20	0.25	WDX 042004	
14.5	●		145D2S20	32	47	91				0.20		
15.0	●		150D2S20	33	48	92				0.15		
15.5	●		WDX 155D2S20	34	49	93				0.40		
16.0	●		160D2S20	35	50	94	44	30.0	20	0.40	WDX 052504	
16.5	●		165D2S20	36	51	95				0.35		
17.0	●		170D2S20	37	52	96				0.30		
17.5	●		WDX 175D2S25	38	53	109	56	32.0	25	0.25		
18.0	●		180D2S25	39	54	110				0.20		
18.5	●		WDX 185D2S25	40	55	111				0.50		
19.0	●		190D2S25	41	56	112				0.45		1
19.5	●		195D2S25	42	57	113				0.40		
20.0	●		200D2S25	43	58	114				0.30	WDX 063006	
20.5	●		205D2S25	44	59	115	56	33.0	25	0.30		
21.0	●		210D2S25	45	60	116				0.20		
21.5	●		215D2S25	46	61	117				0.15		
22.0	●		220D2S25	47	62	118				0.10		
22.5	●		225D2S25	48	63	119				0.05		
23.0	●		WDX 230D2S25	49	67	123				0.70		
23.5	●		235D2S25	50	68	124				0.70		
24.0	●		240D2S25	51	69	125	56	37.0	25	0.60		
24.5	●		245D2S25	52	70	126				0.50		
25.0	●		250D2S25	53	71	127				0.50		
25.5	●		WDX 255D2S32	54	74	134				0.45	WDX 073506	
26.0	●		260D2S32	55	75	135				0.40		
26.5	●		265D2S32	56	76	136				0.35		
27.0	●		270D2S32	57	77	137	60	41.0	32	0.25		
27.5	●		275D2S32	58	78	138				0.20		
28.0	●		280D2S32	59	79	139				0.15		
28.5	●		285D2S32	60	80	140				0.10		
29.0	●		WDX 290D2S32	62	83	143				1.00		
29.5	●		295D2S32	63	84	144				0.95		
30.0	●		300D2S32	64	88	148	60		32	0.90		
31.0	●		310D2S32	66	90	150				0.80		
32.0	●		320D2S32	68	92	152				0.70		
30.0	●		WDX 300D2S40	64	88	158				0.90	WDX 094008	2
31.0	●		310D2S40	66	90	160				0.80		
32.0	●		320D2S40	68	92	162				0.70		
33.0	●		330D2S40	70	94	164	70		40	0.55		
34.0	●		340D2S40	72	96	166				0.45		
35.0	●		350D2S40	74	98	168				0.35		
36.0	●		360D2S40	76	100	170				0.20		
37.0	●		WDX 370D2S40	79	109	179				1.00		
38.0	●		380D2S40	81	111	181				1.00		
39.0	●		390D2S40	83	113	183				0.90		
40.0	●		400D2S40	85	115	185				0.80		
41.0	●		410D2S40	87	117	187	70	49.5	40	0.70	WDX 125012	
42.0	●		420D2S40	89	119	189				0.60		
43.0	●		430D2S40	91	121	191				0.50		
44.0	●		440D2S40	93	123	193				0.50		
45.0	●		450D2S40	95	125	195				0.40		

刃径φ30, φ31, φ32はシャンク径φ32とφ40を在庫しています。 ※半径方向オフセット量(最大)
Cutting diameter of φ30, φ31, φ32 are available with shank diameter of φ32 and φ40. *Maximum offset in the radial direction

ホルダ刃径φ46.0~68.0mm

刃径 Diameter DC		在庫 Stock	型番 Cat. No.	首下長 Length LUX	突出長 Over hang LPR	全長 Length OAL	シャンク Shank LS	接続部 Diameter DCSFMS	径 Diameter DCON	半径方向 オフセット量 (最大) Offset	適用チップ Insert	Fig
46.0	●		WDX 460D2S40	97	127	197				1.50		
47.0	●		470D2S40	99	129	199				1.40		
48.0	●		480D2S40	101	131	201				1.30		2
49.0	●		490D2S40	103	133	203				1.20		
50.0	●		500D2S40	105	135	205				1.10	WDX 156012	
51.0	●		510D2S40	107	137	207				1.00		
52.0	●		520D2S40	109	139	209				0.90		
53.0	●		530D2S40	111	141	211				0.80		
54.0	●		540D2S40	113	143	213				0.60		
55.0	●		550D2S40	115	145	215				0.50		
56.0	●		WDX 560D2S40	120	152	222				2.00		
57.0	●		570D2S40	122	154	224				1.80		
58.0	●		580D2S40	124	156	226				1.70		
59.0	●		590D2S40	126	158	228				1.60		
60.0	●		600D2S40	128	160	230				1.50		3
61.0	●		610D2S40	130	162	232				1.40		
62.0	●		620D2S40	132	164	234				1.30	WDX 186012	
63.0	●		630D2S40	134	166	236				1.20		
64.0	●		640D2S40	136	168	238				1.00		
65.0	●		650D2S40	138	170	240				0.90		
66.0	●		660D2S40	140	172	242				0.70		
67.0	●		670D2S40	142	174	244				0.60		
68.0	●		680D2S40	144	176	246				0.50		

※半径方向オフセット量(最大)
*Maximum offset in the radial direction

SumiDrill WDX型 ホルダ型番の読み方

Part number structure of SumiDrill WDX Type holder

WDX 200 D2 S25

刃径 Diameter DC (φ20.0) | ドリル刃長 Drill Length L/D (2D) | シャンク径 Shank Diameter DCON (φ25.0)

部品 Spare Parts

皿ねじ Screw	スパナ Spanner	スパナ Spanner	適用ホルダ Applicable Holders
BFTX01604N	0.3	TRX06	WDX130D2S20 - WDX150D2S20
BFTX0204N	0.5	TRX06	WDX155D2S20 - WDX180D2S25
BFTY02206	1.0	TRD07	WDX185D2S25 - WDX225D2S25
BFTX02506N	1.5	TRD08	WDX230D2S25 - WDX285D2S32
BFTX03584	3.5	TRD15	WDX290D2S32 - WDX360D2S40
BFTX0511N	5.0	TRD20	WDX370D2S40 - WDX450D2S40
BFTX0615N	5.0	TRD25	WDX460D2S40 - WDX680D2S40

推奨締め付けトルク (N・m)
Recommended Tightening Torque

SumiDrill WDX型 (2D用)

SumiDrill WDX Type

炭素鋼 ~0.28%	合金鋼 0.29%~	調質鋼	高硬度鋼 ~45HRC	ステン レス鋼 46HRC~	Ti合金	耐熱鋼	鋳鉄	ダクタイル 鋳鉄	アルミ 合金	銅合金	複合材 CFRP
◎	◎		○	◎			◎	◎	◎		



加工公差の目安 Range of machining tolerance : -0.05 ~ +0.15

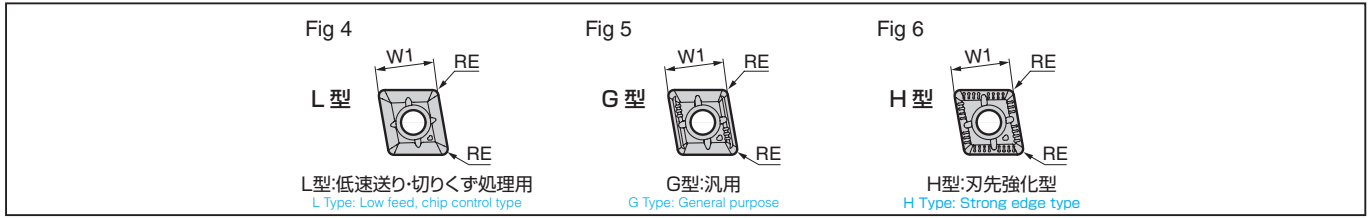

チップ Insert

材種分類 Grade		コーティング Coating									
適用加工 Application	高速・軽切削 High Speed/Light	●	●	●	●	P 鋼 Steel	M ステンレス鋼 Stainless Steel	K 鋳鉄 Cast Iron	N 非鉄金属 Non-Ferrous Metal	S 難削材 Exotic Alloy	H 高硬度材 Hardened Steel
	汎用切削 General Purpose	●	●	●	●						
	粗切削 Rough cutting	●	●	●	●						
型番 Cat. No.	ACP100	ACP300	ACK300	DL1500	Fig	幅 Width W1	厚さ Thickness S	コーナー Radius RE	適用ホルダ Applicable Holders		
WDXT 042004-L	●	●	●		4				WDX130D2S20		
042004-G	●	●	●	●	5	4.2	2.0	0.4	~WDX150D2S20		
042004-H	●	●	●		6						
WDXT 052504-L	●	●	●		4				WDX155D2S20		
052504-G	●	●	●	●	5	5.0	2.5	0.4	~WDX180D2S25		
052504-H	●	●	●		6						
WDXT 063006-L	●	●	●		4				WDX185D2S25		
063006-G	●	●	●	●	5	6.0	3.0	0.6	~WDX225D2S25		
063006-H	●	●	●		6						
WDXT 073506-L	●	●	●		4				WDX230D2S25		
073506-G	●	●	●	●	5	7.5	3.5	0.6	~WDX285D2S32		
073506-H	●	●	●		6						
WDXT 094008-L	●	●	●		4				WDX290D2S32		
094008-G	●	●	●	●	5	9.6	4.0	0.8	~WDX360D2S40		
094008-H	●	●	●		6						
WDXT 125012-L	●	●	●		4				WDX370D2S40		
125012-G	●	●	●	●	5	12.4	5.0	1.2	~WDX450D2S40		
125012-H	●	●	●		6						
WDXT 156012-L	●	●	●		4				WDX460D2S40		
156012-G	●	●	●	●	5	15.2	6.0	1.2	~WDX550D2S40		
156012-H	●	●	●		6						
WDXT 186012-L	●	●	●		4				WDX560D2S40		
186012-G	●	●	●	●	5	18.0	6.0	1.2	~WDX680D2S40		
186012-H	●	●	●		6						

寸法 Dimensions (mm)

SumiDrill WDX型 チップ型番の読み方

Part number structure of SumiDrill WDX Type insert

WDXT 06 30 06 -G

対辺寸法 Width Across Flats (6.0) | 厚さ Thickness × 10 (3.0) | プレーカ種類 Breaker Type | コーナーR Corner Radius × 10 (0.6)

推奨切削条件(2D用) Recommended Cutting Conditions (2D)

<下限値-推奨値-上限値> <Minimum value - Recommended value - Maximum value>

被削材 Work Material	ワーク硬度 Hardness of workpiece HB	推奨 プレーカ Recommended Chipbreaker	推奨チップ 材種 Recommended Insert Grade	Vc 切削速度 Cutting Speed (m/min)	f 送り量 Feed Rate (mm/rev)					
					φ13.0~φ18.0	φ18.5~φ29.0	φ29.5~φ36.0	φ37.0~φ55.0	φ56.0~φ68.0	
P 鋼, 炭素鋼 Steel, Carbon Steel	SS400	125	G	ACP300	120-180-240	0.05-0.08-0.10	0.05-0.08-0.10	0.05-0.08-0.11	0.05-0.08-0.12	0.06-0.09-0.13
	S15C	125	L	ACP300	130-170-220	0.04-0.08-0.12	0.04-0.08-0.12	0.04-0.08-0.13	0.05-0.10-0.15	0.06-0.11-0.17
	S45C	190	G	ACP300	100-150-200	0.08-0.13-0.24	0.08-0.13-0.24	0.08-0.14-0.26	0.09-0.16-0.29	0.10-0.17-0.32
	S45C 焼入れ Hardened	250	G	ACP100	100-170-240	0.05-0.09-0.14	0.05-0.09-0.14	0.05-0.09-0.14	0.05-0.10-0.17	0.06-0.11-0.18
	S75C	270	G	ACP100	120-180-240	0.06-0.10-0.17	0.06-0.10-0.17	0.06-0.10-0.17	0.07-0.12-0.19	0.08-0.13-0.21
	S75C 焼入れ Hardened	300	G	ACP100	85-150-210	0.05-0.09-0.14	0.05-0.09-0.14	0.05-0.09-0.14	0.05-0.10-0.15	0.06-0.11-0.17
2D 低合金鋼 Low Alloy Steel	SCM,SNCM	180	L	ACP300	100-140-180	0.05-0.08-0.14	0.05-0.08-0.14	0.05-0.08-0.16	0.06-0.09-0.17	0.07-0.10-0.19
	SCM,SNCM 焼入れ Hardened	275	G	ACP100	100-170-240	0.06-0.10-0.14	0.06-0.10-0.14	0.06-0.10-0.14	0.07-0.11-0.16	0.08-0.11-0.17
	SCM,SNCM 焼入れ Hardened	300	G	ACP100	90-150-210	0.06-0.10-0.14	0.06-0.10-0.14	0.06-0.10-0.14	0.07-0.11-0.16	0.08-0.11-0.17
	SCM,SNCM 焼入れ Hardened	350	G	ACP100	75-120-165	0.06-0.10-0.14	0.06-0.10-0.14	0.06-0.10-0.14	0.07-0.11-0.16	0.08-0.11-0.17
高合金鋼 High Alloy Steel	SKD,SKT,SKH	200	G	ACP100	120-180-240	0.08-0.12-0.17	0.08-0.12-0.17	0.08-0.12-0.18	0.09-0.12-0.21	0.10-0.13-0.22
	SKD,SKT,SKH 焼入れ Hardened	325	G	ACP100	100-140-180	0.06-0.10-0.15	0.06-0.10-0.15	0.06-0.11-0.15	0.07-0.11-0.16	0.08-0.11-0.17
M ステンレス鋼 Stainless Steel	SUS403 他 (マルテンサイト/フェライト)	200	G	ACP300	100-140-180	0.06-0.11-0.18	0.06-0.11-0.18	0.06-0.12-0.19	0.07-0.13-0.22	0.08-0.14-0.24
	SUS403 他 (マルテンサイト系 焼入れ)	240	G	ACP300	90-120-150	0.06-0.11-0.18	0.06-0.11-0.18	0.06-0.12-0.19	0.07-0.13-0.22	0.08-0.14-0.24
	SUS403 他 (マルテンサイト系 焼入れ)	240	G	ACP300	90-120-150	0.06-0.11-0.18	0.06-0.11-0.18	0.06-0.12-0.19	0.07-0.13-0.22	0.08-0.14-0.24
	SUS304, SUS316 オーステナイト系	180	G	ACP300	100-140-180	0.06-0.11-0.18	0.06-0.11-0.18	0.06-0.12-0.19	0.07-0.13-0.22	0.08-0.14-0.24
K 鋳鉄 Cast Iron	ダクタイル鋳鉄 Ductile Cast Iron		H	ACK300	120-160-200	0.09-0.20-0.32	0.10-0.22-0.36	0.11-0.24-0.39	0.12-0.26-0.44	0.13-0.29-0.48
	ダクタイル鋳鉄 Ductile Cast Iron		H	ACK300	90-120-150	0.09-0.20-0.32	0.10-0.22-0.36	0.11-0.24-0.39	0.12-0.26-0.44	0.13-0.29-0.48
S 難削材 (耐熱合金, 超合金, Ti合金 etc.) Exotic Alloy (Heat Resistant Alloy, Super Alloy, Ti Alloy, etc.)		200	G	ACP300	25-50-70	0.06-0.11-0.18	0.06-0.11-0.18	0.06-0.12-0.19	0.07-0.13-0.22	0.08-0.14-0.24
N アルミニウム合金 Aluminium Alloy			G	DL1500	200-260-320	0.06-0.11-0.17	0.06-0.11-0.17	0.06-0.12-0.18	0.07-0.13-0.20	0.08-0.14-0.22
	銅合金 Copper Alloy		G	DL1500	180-230-280	0.06-0.11-0.17	0.06-0.11-0.17	0.06-0.12-0.18	0.07-0.13-0.20	0.08-0.14-0.22

P種、K種で第一推奨チップ材種がACP300、ACK300の場合の第二推奨チップ材種は、ACP100になります。

この時の推奨切削条件は、切削速度Vcは上表の130%、送り量fは75%を目安としてください。

If the first recommended insert grades for P and K products are ACP300 and ACK300, the second recommended grade will be ACP100. In such cases, please use a cutting speed vc of 130% in the table above and a feed rate f of 75% for the recommended cutting conditions.

●印: 標準在庫品 ●印: 標準在庫品(拡充品) 無印: 受注生産品
●: mark: Standard stock item, ●: mark: Standard stock item(expanded), no mark: made to order item

SumiDrill WDX型 (3D用)

SumiDrill WDX Type

炭素鋼 合金鋼 ~0.28% C 0.23%~	調質鋼	高硬度鋼 ~45HRC 46HRC~	ステン レス鋼	Ti合金	耐熱鋼	鋳鉄	タタリ 鋳鉄	アルミ 合金	銅合金	複合材 CFRP
◎	◎	○	◎	○	○	◎	◎	◎	◎	◎



加工公差の目安 Range of machining tolerance : 0 ~ +0.20

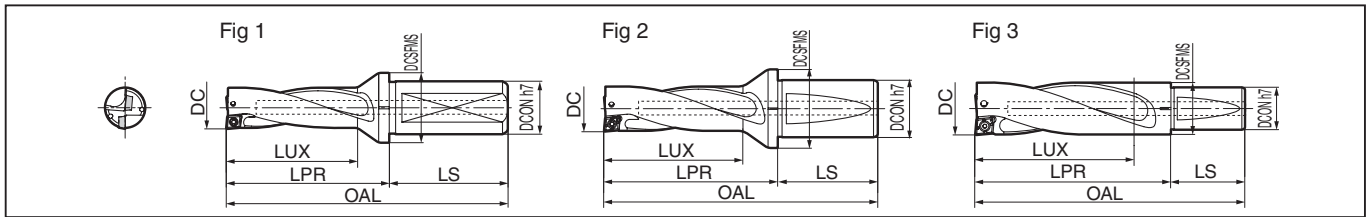

ホルダ刃径φ13.0~45.0mm

刃径 Diameter DC		在庫 Stock	型番 Cat. No.	首下長 Length LUX	突出長 Over hang LPR	全長 Length OAL	シャンク Shank LS	接続部 Diameter DCSFMS	径 Diameter DCON	半径方向 オフセット量 (最大) Offset	適用チップ Insert	Fig
13.0	●	WDX 130D3S20	42.0	57.0	101.0					0.35		
13.5	●	135D3S20	43.5	58.5	102.5					0.30		
14.0	●	140D3S20	45.0	60.0	104.0	44	28.0	20		0.25	WDX 042004	
14.5	●	145D3S20	46.5	61.5	105.5					0.20		
15.0	●	150D3S20	48.0	63.0	107.0					0.15		
15.5	●	WDX 155D3S20	49.5	64.5	108.5					0.40		
16.0	●	160D3S20	51.0	66.0	110.0	44	30.0	20		0.40		
16.5	●	165D3S20	52.5	67.5	111.5					0.35	WDX 052504	
17.0	●	170D3S20	54.0	69.0	113.0					0.30		
17.5	●	WDX 175D3S25	55.5	70.5	126.5					0.25		
18.0	●	180D3S25	57.0	72.0	128.0	56	32.0	25		0.20		
18.5	●	WDX 185D3S25	58.5	73.5	129.5					0.50		
19.0	●	190D3S25	60.0	75.0	131.0					0.45		1
19.5	●	195D3S25	61.5	76.5	132.5					0.40		
20.0	●	200D3S25	63.0	78.0	134.0					0.30	WDX 063006	
20.5	●	205D3S25	64.5	79.5	135.5	56	33.0	25		0.30		
21.0	●	210D3S25	66.0	81.0	137.0					0.20		
21.5	●	215D3S25	67.5	82.5	138.5					0.15		
22.0	●	220D3S25	69.0	84.0	140.0					0.10		
22.5	●	225D3S25	70.5	85.5	141.5					0.05		
23.0	●	WDX 230D3S25	72.0	90.0	146.0					0.70		
23.5	●	235D3S25	73.5	91.5	147.5					0.70		
24.0	●	240D3S25	75.0	93.0	149.0	56	37.0	25		0.60		
24.5	●	245D3S25	76.5	94.5	150.5					0.50		
25.0	●	250D3S25	78.0	96.0	152.0					0.50		
25.5	●	WDX 255D3S32	79.5	99.5	159.5					0.45	WDX 073506	
26.0	●	260D3S32	81.0	101.0	161.0					0.40		
26.5	●	265D3S32	82.5	102.5	162.5					0.35		
27.0	●	270D3S32	84.0	104.0	164.0	60	41.0	32		0.25		
27.5	●	275D3S32	85.5	105.5	165.5					0.20		
28.0	●	280D3S32	87.0	107.0	167.0					0.15		
28.5	●	285D3S32	88.5	108.5	168.5					0.10		
29.0	●	WDX 290D3S32	91.0	112.0	172.0					1.00		
29.5	●	295D3S32	92.5	113.5	173.5					0.95		
30.0	●	300D3S32	94.0	118.0	178.0	60		32		0.90		
31.0	●	310D3S32	97.0	121.0	181.0					0.80		
32.0	●	320D3S32	100.0	124.0	184.0					0.70		
30.0	●	WDX 300D3S40	94.0	118.0	188.0					0.90	WDX 094008	2
31.0	●	310D3S40	97.0	121.0	191.0					0.80		
32.0	●	320D3S40	100.0	124.0	194.0					0.70		
33.0	●	330D3S40	103.0	127.0	197.0	70		40		0.55		
34.0	●	340D3S40	106.0	130.0	200.0					0.45		
35.0	●	350D3S40	109.0	133.0	203.0					0.35		
36.0	●	360D3S40	112.0	136.0	206.0					0.20		
37.0	●	WDX 370D3S40	116.0	146.0	216.0					1.00		
38.0	●	380D3S40	119.0	149.0	219.0					1.00		
39.0	●	390D3S40	122.0	152.0	222.0					0.90		
40.0	●	400D3S40	125.0	155.0	225.0					0.80		
41.0	●	410D3S40	128.0	158.0	228.0	70	49.5	40		0.70	WDX 125012	
42.0	●	420D3S40	131.0	161.0	231.0					0.60		
43.0	●	430D3S40	134.0	164.0	234.0					0.50		
44.0	●	440D3S40	137.0	167.0	237.0					0.50		
45.0	●	450D3S40	140.0	170.0	240.0					0.40		

刃径φ30, φ31, φ32はシャンク径φ32とφ40を在庫しています。 ※半径方向オフセット量(最大)
Cutting diameter of φ30, φ31, φ32 are available with shank diameter of φ32 and φ40. *Maximum offset in the radial direction

ホルダ刃径φ46.0~68.0mm

刃径 Diameter DC		在庫 Stock	型番 Cat. No.	首下長 Length LUX	突出長 Over hang LPR	全長 Length OAL	シャンク Shank LS	接続部 Diameter DCSFMS	径 Diameter DCON	半径方向 オフセット量 (最大) Offset	適用チップ Insert	Fig
46.0	●	WDX 460D3S40	143.0	173.0	243.0					1.50		
47.0	●	470D3S40	146.0	176.0	246.0					1.40		
48.0	●	480D3S40	149.0	179.0	249.0					1.30		2
49.0	●	490D3S40	152.0	182.0	252.0					1.20		
50.0	●	500D3S40	155.0	185.0	255.0					1.10	WDX 156012	
51.0	●	510D3S40	158.0	188.0	258.0					1.00		
52.0	●	520D3S40	161.0	191.0	261.0					0.90		
53.0	●	530D3S40	164.0	194.0	264.0					0.80		
54.0	●	540D3S40	167.0	197.0	267.0					0.60		
55.0	●	550D3S40	170.0	200.0	270.0					0.50		
56.0	●	WDX 560D3S40	176.0	208.0	278.0					2.00		
57.0	●	570D3S40	179.0	211.0	281.0					1.80		
58.0	●	580D3S40	182.0	214.0	284.0					1.70		
59.0	●	590D3S40	185.0	217.0	287.0					1.60		
60.0	●	600D3S40	188.0	220.0	290.0					1.50		3
61.0	●	610D3S40	191.0	223.0	293.0					1.40	WDX 186012	
62.0	●	620D3S40	194.0	226.0	296.0	70		60.0	40	1.30		
63.0	●	630D3S40	197.0	229.0	299.0					1.20		
64.0	●	640D3S40	200.0	232.0	302.0					1.00		
65.0	●	650D3S40	203.0	235.0	305.0					0.90		
66.0	●	660D3S40	206.0	238.0	308.0					0.70		
67.0	●	670D3S40	209.0	241.0	311.0					0.60		
68.0	●	680D3S40	212.0	244.0	314.0					0.50		

※半径方向オフセット量(最大)
*Maximum offset in the radial direction

SumiDrill WDX型 ホルダ型番の読み方
Part number structure of SumiDrill WDX Type holder

WDX 200 D3 S25

刃径 Diameter DC (φ20.0) | ドリル刃長 Drill Length L/D (3D) | シャンク径 Shank Diameter DCON (φ25.0)

部品 Spare Parts

皿ねじ Screw	スパナ Spanner	スパナ Spanner	適用ホルダ Applicable Holders
BFTX01604N	0.3	TRX06	WDX130D3S20 - WDX150D3S20
BFTX0204N	0.5	TRX06	WDX155D3S20 - WDX180D3S25
BFTX02206	1.0	—	WDX185D3S25 - WDX225D3S25
BFTX02506N	1.5	—	WDX230D3S25 - WDX285D3S32
BFTX03584	3.5	—	WDX290D3S32 - WDX360D3S40
BFTX0511N	5.0	—	WDX370D3S40 - WDX450D3S40
BFTX0615N	5.0	—	WDX460D3S40 - WDX680D3S40

推奨締め付けトルク (N・m)
Recommended Tightening Torque

SumiDrill WDX型 (3D用)

SumiDrill WDX Type

炭素鋼 合金鋼 ~0.28% 0.29%~	調質鋼	高硬度鋼 ~45HRC 46HRC~	ステン レス鋼	Ti合金	耐熱鋼	鋳鉄	ダクタイル 鋳鉄	アルミ 合金	銅合金	複合材 CFRP
◎◎	◎	◎	◎			◎	◎	◎		



加工公差の目安 Range of machining tolerance : 0 ~ +0.20

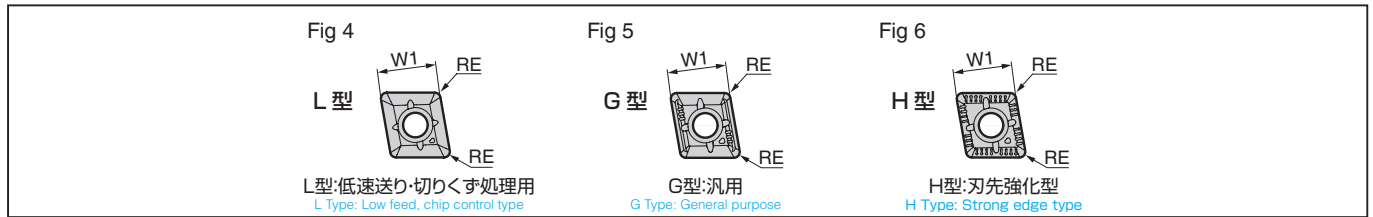

チップ Insert

材種分類 Grade		コーティング Coating				適用加工 Application				適応ホルダ Applicable Holders				
型番 Cat. No.	AC100	AC300	ACK300	DL1500	Fig	幅 W1	厚さ S	コーナー 半径 RE	鋼 Steel	ステンレス鋼 Stainless Steel	鋳鉄 Cast Iron	非鉄金属 Non-Ferrous Metal	難削材 Exotic Alloy	高硬度材 Hardened Steel
WDXT 042004-L	●	●	●		4				●					
042004-G	●	●	●	●	5	4.2	2.0	0.4	●					
042004-H	●	●	●		6									
WDXT 052504-L	●	●	●		4				●					
052504-G	●	●	●	●	5	5.0	2.5	0.4	●					
052504-H	●	●	●		6									
WDXT 063006-L	●	●	●		4				●					
063006-G	●	●	●	●	5	6.0	3.0	0.6	●					
063006-H	●	●	●		6									
WDXT 073506-L	●	●	●		4				●					
073506-G	●	●	●	●	5	7.5	3.5	0.6	●					
073506-H	●	●	●		6									
WDXT 094008-L	●	●	●		4				●					
094008-G	●	●	●	●	5	9.6	4.0	0.8	●					
094008-H	●	●	●		6									
WDXT 125012-L	●	●	●		4				●					
125012-G	●	●	●	●	5	12.4	5.0	1.2	●					
125012-H	●	●	●		6									
WDXT 156012-L	●	●	●		4				●					
156012-G	●	●	●	●	5	15.2	6.0	1.2	●					
156012-H	●	●	●		6									
WDXT 186012-L	●	●	●		4				●					
186012-G	●	●	●	●	5	18.0	6.0	1.2	●					
186012-H	●	●	●		6									

寸法 Dimensions (mm)

SumiDrill WDX型 チップ型番の読み方

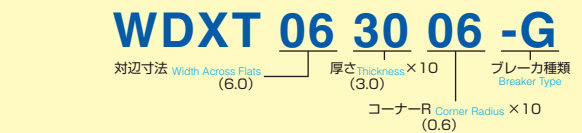

推奨切削条件(3D用) Recommended Cutting Conditions (3D)

<下限値-推奨値-上限値> <Minimum value - Recommended value - Maximum value>

被削材 Work Material	ワーク硬度 Hardness of workpiece HB	推奨 プレーカ Recommended Chip Breaker	推奨チップ 材種 Recommended Insert Grade	Vc 切削速度 Cutting Speed (m/min)	f 送り量 Feed Rate (mm/rev)						
					φ13.0~φ18.0	φ18.5~φ29.0	φ29.5~φ36.0	φ37.0~φ55.0	φ56.0~φ68.0		
P 鋼, 炭素鋼 Steel, Carbon Steel	SS400	125	G	ACP300	120-180-240	0.05-0.07-0.10	0.05-0.07-0.10	0.05-0.08-0.11	0.05-0.08-0.12	0.06-0.09-0.13	
	S15C	125	L	ACP300	130-170-220	0.04-0.07-0.10	0.04-0.07-0.10	0.04-0.08-0.11	0.05-0.09-0.12	0.06-0.10-0.13	
	S45C	190	G	ACP300	100-150-200	0.08-0.12-0.20	0.08-0.12-0.20	0.08-0.13-0.22	0.09-0.14-0.24	0.10-0.16-0.27	
	S45C 焼入れ Hardened	250	G	ACP100	100-170-240	0.05-0.08-0.11	0.05-0.08-0.11	0.05-0.08-0.12	0.05-0.09-0.14	0.06-0.10-0.15	
	S75C	270	G	ACP100	120-180-240	0.06-0.09-0.14	0.06-0.09-0.14	0.06-0.10-0.14	0.07-0.11-0.17	0.08-0.12-0.18	
	S75C 焼入れ Hardened	300	G	ACP100	85-150-210	0.05-0.08-0.11	0.05-0.08-0.11	0.05-0.08-0.11	0.05-0.09-0.14	0.06-0.10-0.14	
	低合金鋼 Low Alloy Steel	SCM,SNCM	180	L	ACP300	100-140-180	0.05-0.07-0.12	0.05-0.07-0.12	0.05-0.08-0.13	0.06-0.08-0.15	0.07-0.09-0.16
		SCM,SNCM 焼入れ Hardened	275	G	ACP100	100-170-240	0.06-0.08-0.11	0.06-0.08-0.11	0.06-0.08-0.11	0.07-0.10-0.12	0.08-0.10-0.13
		SCM,SNCM 焼入れ Hardened	300	G	ACP100	90-150-210	0.06-0.08-0.11	0.06-0.08-0.11	0.06-0.08-0.11	0.07-0.10-0.12	0.08-0.10-0.13
		SCM,SNCM 焼入れ Hardened	350	G	ACP100	75-120-165	0.06-0.08-0.11	0.06-0.08-0.11	0.06-0.08-0.11	0.07-0.10-0.12	0.08-0.10-0.13
高合金鋼 High Alloy Steel	SKD,SKT,SKH	200	G	ACP100	120-180-240	0.08-0.11-0.14	0.08-0.12-0.15	0.08-0.12-0.16	0.09-0.14-0.18	0.10-0.14-0.19	
	SKD,SKT,SKH 焼入れ Hardened	325	G	ACP100	100-140-180	0.06-0.09-0.11	0.06-0.09-0.11	0.06-0.09-0.11	0.07-0.10-0.12	0.08-0.10-0.13	
M ステンレス鋼 Stainless Steel	SUS403他 (マルテンサイト/フェライト)	200	G	ACP300	100-140-180	0.06-0.10-0.15	0.06-0.10-0.15	0.06-0.11-0.16	0.07-0.12-0.18	0.08-0.13-0.20	
	SUS403他 (マルテンサイト系 焼入れ)	240	G	ACP300	90-120-150	0.06-0.10-0.15	0.06-0.10-0.15	0.06-0.11-0.16	0.07-0.12-0.18	0.08-0.13-0.20	
	SUS403他 (オーステナイト系 焼入れ)	180	G	ACP300	100-140-180	0.06-0.10-0.15	0.06-0.10-0.15	0.06-0.11-0.16	0.07-0.12-0.18	0.08-0.13-0.20	
	SUS304,SUS316 オーステナイト系	180	G	ACP300	100-140-180	0.06-0.10-0.15	0.06-0.10-0.15	0.06-0.11-0.16	0.07-0.12-0.18	0.08-0.13-0.20	
K 鋳鉄 Cast Iron	ダクタイル鋳鉄 Ductile Cast Iron		H	ACK300	120-160-200	0.09-0.18-0.27	0.10-0.20-0.30	0.11-0.22-0.32	0.12-0.24-0.36	0.13-0.26-0.40	
	ダクタイル鋳鉄 Ductile Cast Iron		H	ACK300	90-120-150	0.09-0.18-0.27	0.10-0.20-0.30	0.11-0.22-0.32	0.12-0.24-0.36	0.13-0.26-0.40	
S 難削材 (耐熱合金, 超合金, Ti合金 etc.) Exotic Alloy (Heat Resistant Alloy, Super Alloy, Ti Alloy, etc.)		200	G	ACP300	25-50-70	0.06-0.10-0.15	0.06-0.10-0.15	0.06-0.11-0.16	0.07-0.12-0.18	0.08-0.13-0.20	
N アルミニウム合金 Aluminium Alloy			G	DL1500	200-260-320	0.06-0.11-0.17	0.06-0.11-0.17	0.06-0.12-0.18	0.07-0.13-0.20	0.08-0.14-0.22	
	銅合金 Copper Alloy		G	DL1500	180-230-280	0.06-0.11-0.17	0.06-0.11-0.17	0.06-0.12-0.18	0.07-0.13-0.20	0.08-0.14-0.22	

P種、K種で第一推奨チップ材種がACP300、ACK300の場合の第二推奨チップ材種は、ACP100になります。

この時の推奨切削条件は、切削速度Vcは上表の130%、送り量fは75%を目安としてください。

If the first recommended insert grades for P and K products are ACP300 and ACK300, the second recommended grade will be ACP100. In such cases, please use a cutting speed vc of 130% in the table above and a feed rate f of 75% for the recommended cutting conditions.

●印: 標準在庫品 ●印: 標準在庫品(拡充品) 無印: 受注生産品
●: mark: Standard stock item, ●: mark: Standard stock item(expanded), no mark: made to order item

SumiDrill WDX型 (4D用)

SumiDrill WDX Type

炭素鋼・合金鋼 ~0.28% C 0.23%~	調質鋼	高硬度鋼 ~45HRC 46HRC~	ステン レス鋼	Ti合金	耐熱鋼	鋳鉄	タタリ 鋼鉄	アルミ 合金	銅合金	複合材 CFRP
◎	◎	○	◎			◎	◎	◎		



加工公差の目安 Range of machining tolerance : 0 ~ +0.25

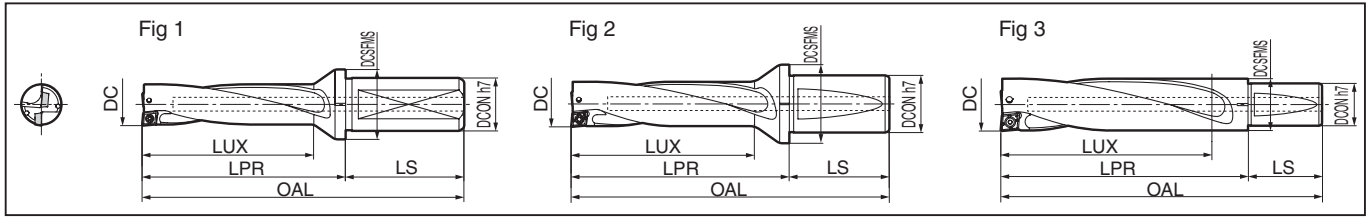

ホルダ刃径φ13.0~45.0mm

刃径 Diameter DC		在庫 Stock	型番 Cat. No.	首下長 Length LUX	突出長 Over hang LPR	全長 Length OAL	シャンク Shank LS	接続部 Diameter DCSFMS	径 Diameter DCON	半径方向 オフセット量 (最大) Offset	適用チップ Insert	Fig
13.0	●	WDX 130D4S20	55	70	114					0.35		
13.5	●	135D4S20	57	72	116					0.30		
14.0	●	140D4S20	59	74	118	44	28.0	20		0.25	WDX 042004	
14.5	●	145D4S20	61	76	120					0.20		
15.0	●	150D4S20	63	78	122					0.15		
15.5	●	WDX 155D4S20	65	80	124					0.40		
16.0	●	160D4S20	67	82	126	44	30.0	20		0.40	WDX 062504	
16.5	●	165D4S20	69	84	128					0.35		
17.0	●	170D4S20	71	86	130					0.30		
17.5	●	WDX 175D4S25	73	88	144	56	32.0	25		0.25		
18.0	●	180D4S25	75	90	146					0.20		
18.5	●	WDX 185D4S25	77	92	148					0.50		
19.0	●	190D4S25	79	94	150					0.45		1
19.5	●	195D4S25	81	96	152					0.40		
20.0	●	200D4S25	83	98	154					0.30		
20.5	●	205D4S25	85	100	156	56	33.0	25		0.30	WDX 063006	
21.0	●	210D4S25	87	102	158					0.20		
21.5	●	215D4S25	89	104	160					0.15		
22.0	●	220D4S25	91	106	162					0.10		
22.5	●	225D4S25	93	108	164					0.05		
23.0	●	WDX 230D4S25	95	113	169					0.70		
23.5	●	235D4S25	97	115	171					0.70		
24.0	●	240D4S25	99	117	173	56	37.0	25		0.60		
24.5	●	245D4S25	101	119	175					0.50		
25.0	●	250D4S25	103	121	177					0.50		
25.5	●	WDX 255D4S32	105	125	185					0.45	WDX 073506	
26.0	●	260D4S32	107	127	187					0.40		
26.5	●	265D4S32	109	129	189					0.35		
27.0	●	270D4S32	111	131	191	60	41.0	32		0.25		
27.5	●	275D4S32	113	133	193					0.20		
28.0	●	280D4S32	115	135	195					0.15		
28.5	●	285D4S32	117	137	197					0.10		
29.0	●	WDX 290D4S32	120	141	201					1.00		
29.5	●	295D4S32	122	143	203	50.0				0.95		
30.0	●	300D4S32	124	148	208	60		32		0.90		
31.0	●	310D4S32	128	152	212					0.80		
32.0	●	320D4S32	132	156	216					0.70		
30.0	●	WDX 300D4S40	124	148	218					0.90	WDX 094008	2
31.0	●	310D4S40	128	152	222					0.80		
32.0	●	320D4S40	132	156	226					0.70		
33.0	●	330D4S40	136	160	230	70		40		0.55		
34.0	●	340D4S40	140	164	234					0.45		
35.0	●	350D4S40	144	168	238					0.35		
36.0	●	360D4S40	148	172	242					0.20		
37.0	●	WDX 370D4S40	153	183	253					1.00		
38.0	●	380D4S40	157	187	257					1.00		
39.0	●	390D4S40	161	191	261					0.90		
40.0	●	400D4S40	165	195	265					0.80		
41.0	●	410D4S40	169	199	269	70	49.5	40		0.70	WDX 125012	
42.0	●	420D4S40	173	203	273					0.60		
43.0	●	430D4S40	177	207	277					0.50		
44.0	●	440D4S40	181	211	281					0.50		
45.0	●	450D4S40	185	215	285					0.40		

刃径φ30, φ31, φ32はシャンク径φ32とφ40を在庫しています。 ※半径方向オフセット量(最大)
Cutting diameter of φ30, φ31, φ32 are available with shank diameter of φ32 and φ40. *Maximum offset in the radial direction

ホルダ刃径φ46.0~63.0mm

刃径 Diameter DC		在庫 Stock	型番 Cat. No.	首下長 Length LUX	突出長 Over hang LPR	全長 Length OAL	シャンク Shank LS	接続部 Diameter DCSFMS	径 Diameter DCON	半径方向 オフセット量 (最大) Offset	適用チップ Insert	Fig
46.0	●	WDX 460D4S40	189	219	289					1.50		
47.0	●	470D4S40	193	223	293					1.40		
48.0	●	480D4S40	197	227	297					1.30		2
49.0	●	490D4S40	201	231	301					1.20		
50.0	●	500D4S40	205	235	305					1.10	WDX 156012	
51.0	●	510D4S40	209	239	309	70				1.00		
52.0	●	520D4S40	213	243	313					0.90		
53.0	●	530D4S40	217	247	317					0.80		
54.0	●	540D4S40	221	251	321					0.60		
55.0	●	550D4S40	225	255	325					0.50		
56.0	●	WDX 560D4S40	232	264	334					2.00		
57.0	●	570D4S40	236	268	338					1.80		3
58.0	●	580D4S40	240	272	342					1.70		
59.0	●	590D4S40	244	276	346					1.60	WDX 186012	
60.0	●	600D4S40	248	280	350	70				1.50		
61.0	●	610D4S40	252	284	354					1.40		
62.0	●	620D4S40	256	288	358					1.30		
63.0	●	630D4S40	260	292	362					1.20		

※半径方向オフセット量(最大)
*Maximum offset in the radial direction

SumiDrill WDX型 ホルダ型番の読み方
Part number structure of SumiDrill WDX Type holder

WDX 200 D4 S25

刃径 Diameter DC (φ20.0) | ドリル刃長 Drill Length L/D (4D) | シャンク径 Shank Diameter DCON (φ25.0)

部品 Spare Parts

皿ねじ Screw	スパナ Spanner	スパナ Spanner	適用ホルダ Applicable Holders
BFTX01604N	0.3	TRX06	WDX130D4S20 - WDX150D4S20
BFTX0204N	0.5	TRX06	WDX155D4S20 - WDX180D4S25
BFTY02206	1.0	—	TRD07
BFTX02506N	1.5	—	TRD08
BFTX03584	3.5	—	TRD15
BFTX0511N	5.0	—	TRD20
BFTX0615N	5.0	—	TRD25

推奨締め付けトルク (N・m)
Recommended Tightening Torque

SumiDrill WDX型 (5D用)

SumiDrill WDX Type

炭素鋼 合金鋼 ~0.28% C 0.23%~	調質鋼	高硬度鋼 ~45HRC 46HRC~	ステン レス鋼	Ti合金	耐熱鋼	鋳鉄	タタリ 鋳鉄	アルミ 合金	銅合金	複合材 CFRP
◎	◎	○	◎			◎	◎	◎		



加工公差の目安 Range of machining tolerance : 0 ~ +0.25

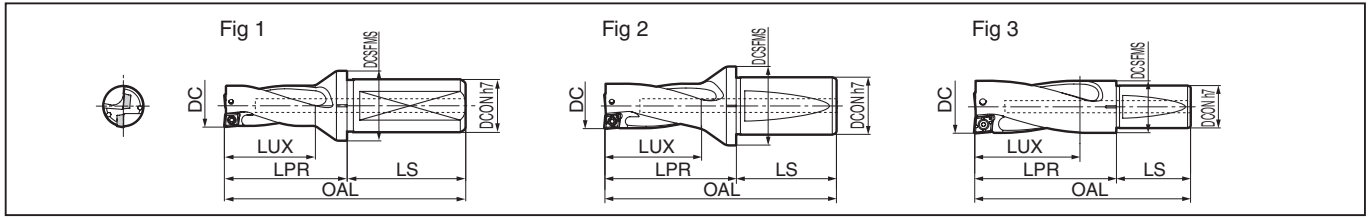

ホルダ刃径φ13.0~45.0mm

Holder Diameter		Dimensions (寸法: mm)									
刃径 Diameter DC	在庫 Stock	型番 Cat. No.	首下長 Length LUX	突出長 Over hang LPR	全長 Length OAL	シャンク Shank LS	接続部 Diameter DCSFMS	径 Diameter DCON	半径方向 オフセット量 (最大) Offset	適用チップ Insert	Fig
13.0	●	WDX 130D5S20	68.0	83.0	127.0				0.35		
13.5	●	135D5S20	70.5	85.5	129.5				0.30		
14.0	●	140D5S20	73.0	88.0	132.0	44	28.0	20.0	0.25	WDX 042004	
14.5	●	145D5S20	75.5	90.5	134.5				0.20		
15.0	●	150D5S20	78.0	93.0	137.0				0.15		
15.5	●	WDX 155D5S20	80.5	95.5	139.5				0.40		
16.0	●	160D5S20	83.0	98.0	142.0	44	30.0	20.0	0.40		
16.5	●	165D5S20	85.5	100.5	144.5				0.35	WDX 052504	
17.0	●	170D5S20	88.0	103.0	147.0				0.30		
17.5	●	WDX 175D5S25	90.5	105.5	161.5	56	32.0	25.0	0.25		
18.0	●	180D5S25	93.0	108.0	164.0				0.20		
18.5	●	WDX 185D5S25	95.5	110.5	166.5				0.50		
19.0	●	190D5S25	98.0	113.0	169.0				0.45		1
19.5	●	195D5S25	100.5	115.5	171.5				0.40		
20.0	●	200D5S25	103.0	118.0	174.0				0.30	WDX 063006	
20.5	●	205D5S25	105.5	120.5	176.5	56	33.0	25.0	0.30		
21.0	●	210D5S25	108.0	123.0	179.0				0.20		
21.5	●	215D5S25	110.5	125.5	181.5				0.15		
22.0	●	220D5S25	113.0	128.0	184.0				0.10		
22.5	●	225D5S25	115.5	130.5	186.5				0.05		
23.0	●	WDX 230D5S25	118.0	136.0	192.0				0.70		
23.5	●	235D5S25	120.5	138.5	194.5				0.70		
24.0	●	240D5S25	123.0	141.0	197.0	56	37.0	25.0	0.60		
24.5	●	245D5S25	125.5	143.5	199.5				0.50	WDX 073506	
25.0	●	250D5S25	128.0	146.0	202.0				0.50		
26.0	●	WDX 260D5S32	133.0	153.0	213.0				0.40		
27.0	●	270D5S32	138.0	158.0	218.0	60	41.0		0.25		
28.0	●	280D5S32	143.0	163.0	223.0				0.15		
29.0	●	WDX 290D5S32	149.0	170.0	230.0		50.0	32.0	1.00		
30.0	●	300D5S32	154.0	178.0	238.0	60			0.90		
31.0	●	310D5S32	159.0	183.0	243.0				0.80		
32.0	●	320D5S32	164.0	188.0	248.0				0.70		
30.0	●	WDX 300D5S40	154.0	178.0	248.0				0.90	WDX 094008	
31.0	●	310D5S40	159.0	183.0	253.0		54.0		0.80		
32.0	●	320D5S40	164.0	188.0	258.0				0.70		
33.0	●	330D5S40	169.0	193.0	263.0	70		40.0	0.55		2
34.0	●	340D5S40	174.0	198.0	268.0				0.45		
35.0	●	350D5S40	179.0	203.0	273.0				0.35		
36.0	●	360D5S40	184.0	208.0	278.0				0.20		
37.0	●	WDX 370D5S40	190.0	220.0	290.0				1.00		
38.0	●	380D5S40	195.0	225.0	295.0				1.00		
39.0	●	390D5S40	200.0	230.0	300.0				0.90		
40.0	●	400D5S40	205.0	235.0	305.0				0.80		
41.0	●	410D5S40	210.0	240.0	310.0	70	49.5	40.0	0.70	WDX 125012	
42.0	●	420D5S40	215.0	245.0	315.0				0.60		
43.0	●	430D5S40	220.0	250.0	320.0				0.50		
44.0	●	440D5S40	225.0	255.0	325.0				0.50		
45.0	●	450D5S40	230.0	260.0	330.0				0.40		

刃径φ30, φ31, φ32はシャンク径φ32とφ40を在庫しています。
Cutting diameter of φ30, φ31, φ32 are available with shank diameter of φ32 and φ40.

※半径方向オフセット量(最大)
*Maximum offset in the radial direction

ホルダ刃径φ46.0~55.0mm

Holder Diameter		Dimensions (寸法: mm)									
刃径 Diameter DC	在庫 Stock	型番 Cat. No.	首下長 Length LUX	突出長 Over hang LPR	全長 Length OAL	シャンク Shank LS	接続部 Diameter DCSFMS	径 Diameter DCON	半径方向 オフセット量 (最大) Offset	適用チップ Insert	Fig
46.0	●	WDX 460D5S40	235.0	265.0	335.0				1.50		
47.0	●	470D5S40	240.0	270.0	340.0				1.40		
48.0	●	480D5S40	245.0	275.0	345.0				1.30		2
49.0	●	490D5S40	250.0	280.0	350.0			49.5	1.20		
50.0	●	500D5S40	255.0	285.0	355.0			70	1.10	WDX 156012	
51.0	●	510D5S40	260.0	290.0	360.0				1.00		
52.0	●	520D5S40	265.0	295.0	365.0			50.5	0.90		3
53.0	●	530D5S40	270.0	300.0	370.0			51.5	0.80		
54.0	●	540D5S40	275.0	305.0	375.0			52.5	0.60		
55.0	●	550D5S40	280.0	310.0	380.0			53.5	0.50		

※半径方向オフセット量(最大)
*Maximum offset in the radial direction

SumiDrill WDX型 ホルダ型番の読み方
Part number structure of SumiDrill WDX Type holder

WDX 200 D5 S25

刃径 Diameter DC (φ20.0) | ドリル刃長 Drill Length L/D (5D) | シャンク径 Shank Diameter DCON (φ25.0)

部品 Spare Parts

皿ねじ Screw	スパナ Spanner	スパナ Spanner	適用ホルダ Applicable Holders
BFTX01604N	0.3	TRX06	WDX130D5S20 - WDX150D5S20
BFTX0204N	0.5	TRX06	WDX155D5S20 - WDX180D5S25
BFTY02206	1.0	—	WDX185D5S25 - WDX225D5S25
BFTX02506N	1.5	—	WDX230D5S25 - WDX285D5S32
BFTX03584	3.5	—	WDX290D5S32 - WDX360D5S40
BFTX0511N	5.0	—	WDX370D5S40 - WDX450D5S40
BFTX0615N	5.0	—	WDX460D5S40 - WDX550D5S40

推奨締め付けトルク (N・m)
Recommended Tightening Torque

SumiDrill WDX型 (5D用)

SumiDrill WDX Type

炭素鋼 ~0.28%	合金鋼 0.29%~	調質鋼	高硬度鋼 ~45HRC	ステン レス鋼	Ti合金	耐熱鋼	鋳鉄	ダクタ イル鋳鉄	アルミ 合金	銅合金	複合材 CFRP
◎	◎		○	◎			◎	◎	◎		



加工公差の目安 Range of machining tolerance : 0 ~ +0.25

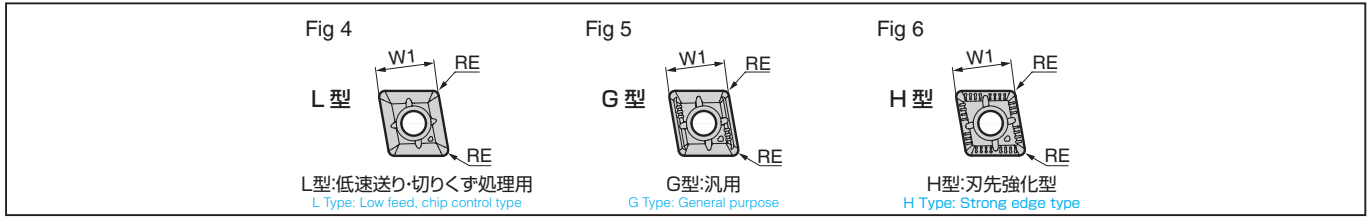

チップ Insert

材種分類 Grade		コーティング Coating								
適用加工 Application	高速・軽切削 High Speed/Light	P			N	幅 Width W1	厚さ Thickness S	コーナー Radius RE	適用ホルダ Applicable Holders	
	汎用切削 General Purpose		F							
	粗切削 Rough cutting		F	K						
型番 Cat. No.	ACP100	ACP300	ACK300	DL1500	Fig	W1	S	RE		
WDXT 042004-L	●	●	●		4				WDX130D5S20	
042004-G	●	●	●	●	5	4.2	2.0	0.4	~WDX150D5S20	
042004-H	●	●	●		6					
WDXT 052504-L	●	●	●		4				WDX155D5S20	
052504-G	●	●	●	●	5	5.0	2.5	0.4	~WDX180D5S25	
052504-H	●	●	●		6					
WDXT 063006-L	●	●	●		4				WDX185D5S25	
063006-G	●	●	●	●	5	6.0	3.0	0.6	~WDX225D5S25	
063006-H	●	●	●		6					
WDXT 073506-L	●	●	●		4				WDX230D5S25	
073506-G	●	●	●	●	5	7.5	3.5	0.6	~WDX285D5S32	
073506-H	●	●	●		6					
WDXT 094008-L	●	●	●		4				WDX290D5S32	
094008-G	●	●	●	●	5	9.6	4.0	0.8	~WDX360D5S40	
094008-H	●	●	●		6					
WDXT 125012-L	●	●	●		4				WDX370D5S40	
125012-G	●	●	●	●	5	12.4	5.0	1.2	~WDX450D5S40	
125012-H	●	●	●		6					
WDXT 156012-L	●	●	●		4				WDX460D5S40	
156012-G	●	●	●	●	5	15.2	6.0	1.2	~WDX550D5S40	
156012-H	●	●	●		6					

寸法 Dimensions (mm)

SumiDrill WDX型 チップ型番の読み方

Part number structure of SumiDrill WDX Type insert

WDXT 06 30 06 -G

対辺寸法 Width Across Flats (6.0) | 厚さ Thickness × 10 (3.0) | プレーキ種類 Breaker Type
コーナーR Corner Radius × 10 (0.6)

推奨切削条件 (5D用) Recommended Cutting Conditions (5D)

<下限値-推奨値-上限値> <Minimum value - Recommended value - Maximum value>

	被削材 Work Material	ワーク硬度 Hardness of workpiece HB	推奨 ブレーカ Recommended Breaker	推奨チップ 材種 Recommended Insert Grade	Vc 切削速度 Cutting Speed (m/min)	f 送り量 Feed Rate (mm/rev)			
						φ13.0~φ18.0	φ18.5~φ29.0	φ29.5~φ36.0	φ37.0~φ55.0
P	鋼, 炭素鋼 Steel, Carbon Steel								
	SS400	125	G	ACP300	120-180-240	0.05-0.06-0.09	0.05-0.06-0.09	0.05-0.06-0.09	0.05-0.07-0.09
	S15C	125	L	ACP300	130-170-220	0.04-0.06-0.08	0.04-0.06-0.08	0.04-0.06-0.08	0.05-0.07-0.09
	S45C	190	G	ACP300	100-150-200	0.07-0.10-0.15	0.07-0.10-0.15	0.08-0.11-0.17	0.09-0.12-0.19
	S45C 焼入れ Hardened	250	G	ACP100	100-170-240	0.04-0.07-0.08	0.04-0.07-0.08	0.05-0.07-0.09	0.05-0.08-0.11
	S75C	270	G	ACP100	120-180-240	0.05-0.08-0.11	0.05-0.08-0.11	0.06-0.08-0.11	0.07-0.09-0.13
	S75C 焼入れ Hardened	300	G	ACP100	85-150-210	0.04-0.07-0.08	0.04-0.07-0.08	0.05-0.07-0.09	0.05-0.08-0.10
	低合金鋼 Low Alloy Steel								
	SCM, SNCM	180	L	ACP300	100-140-180	0.05-0.06-0.09	0.05-0.06-0.09	0.05-0.06-0.10	0.05-0.07-0.11
	SCM, SNCM 焼入れ Hardened	275	G	ACP100	100-170-240	0.04-0.06-0.09	0.04-0.06-0.09	0.04-0.06-0.09	0.05-0.07-0.10
SCM, SNCM 焼入れ Hardened	300	G	ACP100	90-150-210	0.04-0.06-0.09	0.04-0.06-0.09	0.04-0.06-0.09	0.05-0.07-0.10	
SCM, SNCM 焼入れ Hardened	350	G	ACP100	75-120-165	0.04-0.06-0.09	0.04-0.06-0.09	0.04-0.06-0.09	0.05-0.07-0.10	
5D	高合金鋼 High Alloy Steel								
	SKD, SKT, SKH	200	G	ACP100	120-180-240	0.05-0.08-0.12	0.06-0.09-0.12	0.06-0.09-0.13	0.07-0.10-0.14
SKD, SKT, SKH 焼入れ Hardened	325	G	ACP100	100-140-180	0.04-0.06-0.09	0.04-0.06-0.09	0.04-0.06-0.09	0.04-0.06-0.09	
M	ステンレス鋼 Stainless Steel								
	SUS403他 (マルテンサイト/フェライト) SUS403 and others (Martensite/Ferrite)	200	G	ACP300	100-140-180	0.05-0.09-0.11	0.05-0.09-0.11	0.06-0.09-0.12	0.06-0.10-0.14
	SUS403他 マルテンサイト系 (焼入れ) SUS403 and others Martensitic (Hardened)	240	G	ACP300	90-120-150	0.05-0.09-0.11	0.05-0.09-0.11	0.06-0.09-0.12	0.06-0.10-0.14
	SUS304, SUS316 オーステナイト系 SUS304, SUS316 Austenitic	180	G	ACP300	100-140-180	0.05-0.09-0.11	0.05-0.09-0.11	0.06-0.09-0.12	0.06-0.10-0.14
K	鋳鉄 Cast Iron								
	ダクタイル鋳鉄 Ductile Cast Iron		H	ACK300	120-160-200	0.08-0.15-0.21	0.09-0.17-0.23	0.09-0.18-0.25	0.11-0.20-0.28
S	難削材 (耐熱合金, 超合金, Ti合金 etc.) Exotic Alloy (Heat Resistant Alloy, Super Alloy, Ti Alloy, etc.)	200	G	ACP300	25-50-70	0.05-0.09-0.11	0.05-0.09-0.11	0.06-0.09-0.12	0.06-0.10-0.14
N	アルミニウム合金 Aluminium Alloy								
	銅合金 Copper Alloy								

P種、K種で第一推奨チップ材種がACP300、ACK300の場合の第二推奨チップ材種は、ACP100になります。

この時の推奨切削条件は、切削速度Vcは上表の130%、送り量fは75%を目安としてください。

If the first recommended insert grades for P and K products are ACP300 and ACK300, the second recommended grade will be ACP100. In such cases, please use a cutting speed vc of 130% in the table above and a feed rate f of 75% for the recommended cutting conditions.

●印：標準在庫品 ●印：標準在庫品(拡充品) 無印：受注生産品
● mark: Standard stock item, ● mark: Standard stock item(expanded), no mark: made to order item

SumiDrill WDX型専用 偏心スリーブ WAS型

SumiDrill specialized for WDX Type

偏心スリーブ WAS型 Decentered sleeve WAS Type

SumiDrill WDX 型専用 偏心スリーブ「WAS型」を使用することで、加工穴径を $\pm 0.3\text{mm}$ 程度調整することが可能です。
Using SumiDrill specialized for WDX Type, decentered sleeve "WAS Type", the size of machining hole can be adjusted $\pm 0.3\text{mm}$.

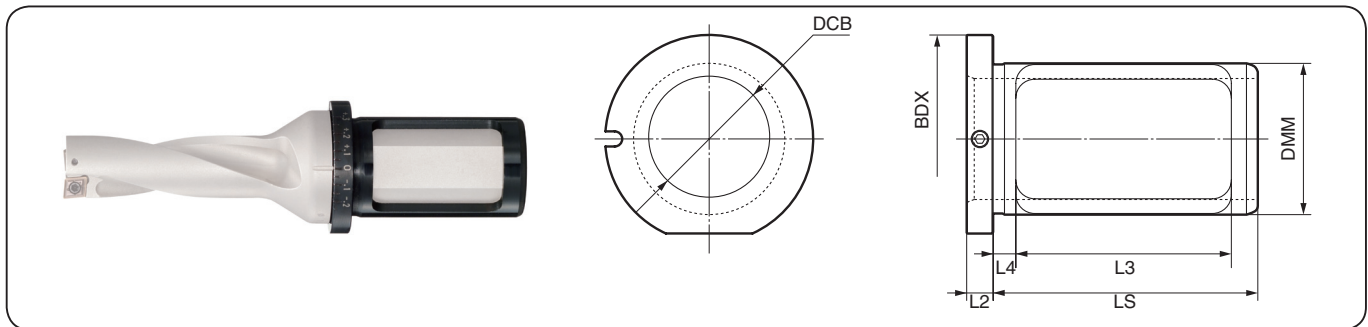

■ 本体 Body (WAS 型 WAS Type)

(寸法 Dimensions : mm)

型番 Cat. No.	在庫 Stock	シャンク Shank DCB	シャンク径 Shank DMM	径 Diameter BDX	シャンク Shank LS	長さ Length L2	長さ Length L3	長さ Length L4	加工径調整範囲 Adjustable range of machining diameter
WAS 2025-48	●	20	25	33	43	5	32	5	+0.3 ~ -0.2
2532-60	●	25	32	42	60	7	46	6	+0.3 ~ -0.3
3240-70	●	32	40	55	70	7	57	6	+0.3 ~ -0.3
4050-85	●	40	50	60	80	7	64	6	+0.3 ~ -0.3

※ 加工径調整範囲は、直径の調整範囲を示します。
*Adjustable range of machining diameter indicates adjustable range of diameter.

■ 使用上のご注意 Important Notes

- 注1. 目盛りは目安ですので、調整後は実際の加工径を測定し、調整してください。
- 注2. コレットチャック式のホルダでは使用できません。サイドロック式のホルダを使用してください。
- 注3. 本製品は剛性の高い加工でご使用ください。
5D などの深穴加工や、低剛性の加工では推奨できません。

Note 1: The dial is for reference purposes. Always measure the actual drilling diameter and adjust accordingly.

Note 2: Not usable with collet chuck type holders. Use a side-locking holder.

Note 3: Use this product on high rigidity drilling processes.

This product is not recommended for deep hole drilling such as 5D and machining of material with low rigidity.

■ 使用方法 (加工径の調整) How to adjust machining diameter

手順 ① Step 1

基準線
Reference line

WAS型 装着イメージ
Conceptual Image of Mounted WAS Type

手順 ③ Step 3

ドリル
固定ネジ
Screw to
fix the drill

ドリルのフランジ部にある線を基準にして、スリーブの目盛りに合わせます。
Spin the dial on the sleeve to the reference line on the drill flange.

手順 ② Step 2

調整目盛り
Adjustment hash marks

加工径を大きくする場合はプラス方向へ、小さくする場合はマイナス方向へスリーブを回して調整してください。
Turn to positive for larger diameter, and to negative for smaller diameter.

ドリル固定ネジを軽く締めて、ドリルを固定してください。
Fasten the screw briefly to fix the drill.

■ 旋盤加工要領 Lathe Machining Guidelines



図 1 Fig. 1

■ ドリルの取付け Drill installation

- ・外周刃が機械の X 軸と平行になるようにセットして下さい。(図 1)
- ・ホルダ端面とドリルのフランジ端面を密着させた状態でボルト締めして下さい。
- ・ Set the drill so that the peripheral insert is parallel to X axis of the machine (Fig. 1).
- ・ Fasten the bolt while the holder edge and the flange edge of the drill are closely attached.

■ 加工径の調整 Adjustment of machining diameter

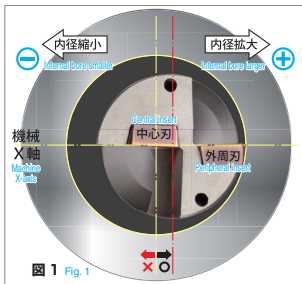
- ・機械の X 軸の移動により調整が可能です。
- ・調整方向は X 軸のプラス側（内径拡大方向）に調整して下さい。マイナス側（内径縮小方向）に調整すると、ホルダが加工した穴に干渉（擦れる）する可能性がありますので、推奨しません。(図 1)
- ・最大調整（オフセット）量はドリル径により異なりますので、**P.8 ~ 15 ホルダ寸法表「半径方向オフセット量（最大）」**を参照下さい。
- ・ Machining diameter can be adjusted by moving X axis of the machine.
- ・ It is always recommended that X axis is moved to positive (direction to expand the inner diameter). Negative direction (direction to shrink the inner diameter) is not recommended because the holder may interfere with (scrape) the machined hole (Refer to Fig. 1).
- ・ The maximum adjustment (offset) varies depending on the drill diameter. Refer to the chart "Maximum offset distance in the radius direction" on p. 8-15.



図 2 Fig. 2

■ その他注意事項 Other important notes

- ・旋盤にドリルを取付けた場合、主軸中心に対して中心刃の芯高が0.15~0.2mm程度芯下がりになるようにドリルは設計されています。
- ・主軸中心のずれが大きく、中心刃が主軸中心より芯上がりになると、中心刃が欠損しますのでご注意ください。
- ・外径加工、または内径ボーリング加工を行う場合、切込みはドリル径の1/5以下(最大5mm以下)に設定下さい。(例:ドリル径 φ20の場合、切込み4mm以下)
- ・旋盤にて貫通加工を行う場合、貫通時に生成された円盤状の切りくず(図2)が飛散することがあります。設備にカバーのないものは、危険防止のためカバーなどを取り付けて下さい。
- ・ When the drill is mounted on a lathe, the core height of the central insert is designed to be 0.15-0.2mm lower than the center of the main axis.
- ・ It is reminded that if the main axis is largely misaligned and the central insert is higher than the center of the main axis, the central insert may be damaged.
- ・ In case of external machining or inner boring machining, the cut depth shall be set to 1/5 or less than the drill diameter (Maximum 5mm or less). (Example: When the drill diameter is φ20, the cut depth is 4mm or less).
- ・ When cutting off the material with a lathe, discoid chips (Fig. 2) created during machining may scatter. If the machine is not equipped with a cover, please install a cover protection to prevent danger.

■ 設備動力値の目安 Typical Power Ratings

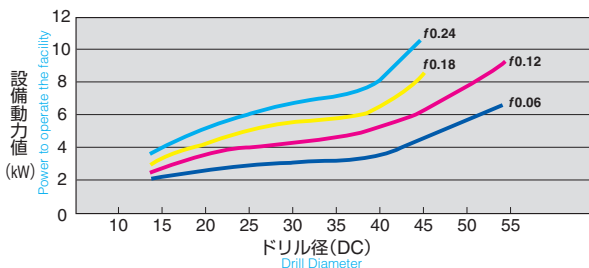

< 注意事項 Note >

■設備動力値は、被削材、切削速度等により変動しますので、参考値として下さい。
Facility power value shown in the graph above is reference only as it changes depending on the work material and the cutting speed.

■ 切削条件(参考値) Cutting conditions (reference values)

被削材 Work material: S50C(230HB)
切削速度 Cutting speed: $v_c = 150\text{m/min}$

■ 切削油吐出量の目安 Typical Coolant Volume

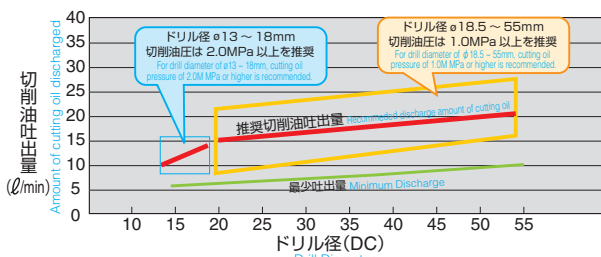

< 注意事項 Note >

■切削油吐出量はドリルの性能を左右する要因の一つです。特に切りくず排出性、潤滑性において重要です。

Discharge amount of cutting oil is an important factor to determine the drill performance, especially for chip evaluation and lubrication performance.

■小径ドリルほど、切削油圧を高めに設定することを推奨します。(φ18.0mm以下)

It is recommended that cutting oil pressure is set higher for drills of smaller diameter (φ18.0mm or less)

■一般的なCNCのマシンでは、切削油圧を調整することができ、切削油吐出量を調整することができます。

The amount of oil discharge on most CNC machines can be adjusted by adjusting the cutting oil pressure.

■この表はガイドラインであり、機械や切削油、ワークによって吐出量を上げる必要があります。

The graphs shown above are reference only. The amount of oil discharge needs to be increased depending on the machine, type of cutting oil and work material.



SumiDrill WDX 型

SumiDrill WDX Type

■ チップ脱着時の注意点 Notes on attaching and detaching inserts

- ・ チップを取付ける前に、チップ座のゴミ等異物をエア等で取り除いて下さい。
- ・ スパナは、ネジの軸とスパナの軸を合わせ、押し付けるように使用下さい。(図 3)
スパナの軸が曲がっていると、チップクランプ不足、スパナの先端、ネジのトルクス穴部が変形する場合がありますので、ご注意下さい。
- ・ チップの取付け時にチップ座面とドリル本体に隙間が生じない様、ご注意願います。(図 4, A部)
正式に取付けた状態は図 4 のようになります。

- ・ Before installing an insert, use an air dust blower to remove foreign particles present on the insert base.
- ・ Spanner axis and screw axis shall be aligned and press the spanner while turning (See Fig. 3).
- ・ If the spanner axis is not aligned, the chip may not be clamped properly and the spanner edge and torx hole may deform.
When the insert is mounted on the chip base, please confirm that there is no clearance between the insert base and the flute (Fig. 4, A).
The appropriate images of the inserted chip are shown in Fig. 4.

※ 中心刃の外側面には隙間がありますが、クランプ面は内側と後側になりますので、使用上問題ありません。
*It is no problem if there is clearance on the external face of the central insert as the clamping surface is inside and back of the insert.

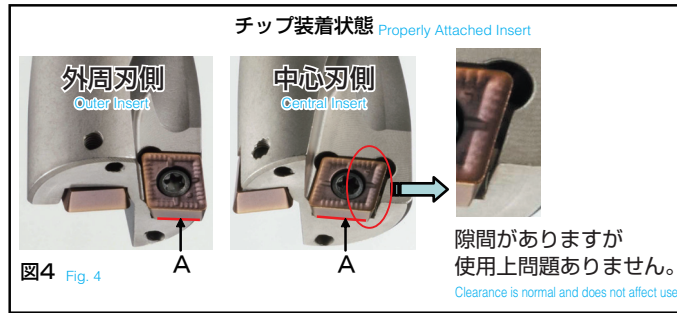
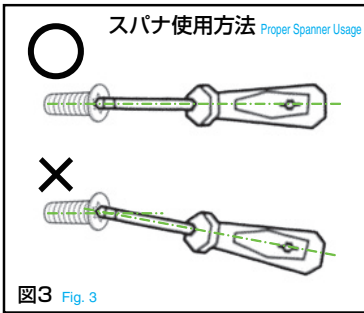

■ トラブルシューティング Troubleshooting

不具合状況 Problem	現象 Symptom	原因 Cause	対策 Countermeasures
加工穴径の変動が大きい Too much variation in hole diameter	加工穴径が狙い値より大きくなる Drilled hole is larger than desired	・ スラストが高くなり、ホルダがたわむ ・ Deflection of the holder due to high thrust force	・ スラストを下げるために、送り速度を下げてください。 ・ X 軸方向で調整を行なってください。 ・ Decrease the feed rate to decrease the thrust force. ・ Make an adjustment on the X axis.
	加工穴径が狙い値より小さくなる Drilled hole is smaller than desired	・ 刃先がワークに食いつかずに逃げてしまっている ・ The cutting edge does not enter into the workpiece but backs off	・ 送り速度を上げてください。 ・ X 軸方向で調整を行なってください。 ・ Increase the feed rate. ・ Make an adjustment on the X axis.
	穴の入口と奥での穴径差が大きい Pronounced difference in hole size at entrance and bottom	・ 切りくずつまり ・ Packing of Chips	・ 送り速度を上げて、切りくず排出を良くする。 ・ 切りくず処理用ブレイカ「L型」を使用。(P.6 参照) ・ Increase the feed rate to improve chip evacuation. ・ Use L type chipbreaker. (See p. 6).
加工穴面が悪い Poor or rough drilled hole surface	穴の入口から奥まで、加工面が悪い Poor drilled surface from entrance to bottom of hole	・ 切削抵抗が高い ・ ワーク剛性が低い ・ High cutting resistance ・ Low rigidity of workpiece	・ 送り速度を下げてください。 ・ ツーリングを見直し、剛性を上げる。 ・ Decrease the feed rate. ・ Review tooling to improve rigidity.
	穴の奥で加工面が悪くなる Poor drilled surface at bottom of hole	・ 切りくずにより加工面が傷つけられる ・ Machined surfaces damaged by chips	・ 送り速度を上げて、切りくず排出を良くする。 ・ 切りくず処理用ブレイカ「L型」を使用。(P.6 参照) ・ Increase the feed rate to improve chip evacuation. ・ Use L type chipbreaker. (See p. 6).
チップが欠損する Insert breakage	中心刃 (中心部) が欠損する Breakage on central insert (centre)	・ 芯高調整不良 ・ チップの強度不足 ・ Improper adjustment of centre height ・ Insert too weak	・ 芯高を再度確認してください。 ・ 旋盤で使用する場合は、ドリルを 180° 回転させて取り付けてみてください。 ・ 刃先強化型ブレイカ「H型」を使用。(P.6 参照) ・ Adjust the height of the insert. ・ If the drill is being used on a lathe, try flipping the drill 180°. ・ Use a strong edge chipbreaker H type.
	外周刃が欠損する Breakage on outer insert	・ 刃先の加工負荷が高い ・ High cutting load in cutting edge	・ 加工負荷を下げるため、送り速度を下げてください。 ・ 刃先強化型ブレイカ「H型」を使用。(P.6 参照) ・ Decrease the feed rate to decrease cutting load. ・ Use a strong edge chipbreaker H type.

■ 使用実例 Application Examples

SumiDrill WDX 型 300ワーク/コーナー
300 workpieces per corner

他社品 Competitor's Product 150ワーク/コーナー
150 workpieces per corner

寿命2倍!
Double tool life!

加工ワーク数
Number of workpieces machined

被削材 Work material : 機械部品 Machine component (FCD450)
使用工具 Tool : WDX205D3S25
チップ Insert : WDXTO63006-G (ACK300)
切削条件 Cutting conditions : $v_c=122\text{m/min}$ $f=0.15\text{mm/rev}$ $H=33\text{mm}$ 貫通 Through Wet

Tool life has been extended twice longer than that of conventional types.
More stable machining performance with less power used for machining.

SumiDrill WDX 型 2400穴/コーナー
2,400 holes per corner

他社品 Competitor's Product 2000穴/コーナー
2,000 holes per corner

寿命20%アップ!
Tool life increased by 20%
能率25%アップ!
Efficiency increased by 25%

加工穴数
No. of Holes

被削材 Work material : 機械部品 Machine component (SCM440)
使用工具 Tool : WDX200D3S25
チップ Insert : WDXTO63006-G (ACP300)
切削条件 Cutting conditions : $v_c=157\text{m/min}$ $f=0.19\text{mm/rev}$ $H=19\text{mm}$ 貫通 Through Wet
他社品切削条件 Competitor's product cutting conditions : $v_c=157\text{m/min}$ $f=0.15\text{mm/rev}$ $H=19\text{mm}$ 貫通 Through Wet

高能率条件においても切りくず処理性良好。また切削時の振動が少なく安定感あり。能率25%、寿命20%向上した。
Chips are well controlled even under high-efficient conditions. Low vibration during machining provides stable performance.

SumiDrill WDX 型 $v_f=127\text{mm/min}$

他社品 Competitor's Product $v_f=32\text{mm/min}$

能率4倍!
Four times more efficient!

送り速度 Feed Rate

加工面、加工穴径共に良好!
Good quality machined surface and hole diameter.

入口 : $\phi 60.155$
出口 : $\phi 60.157$

被削材 Work material : プレート Steel plate (S48C) 使用工具 Tool : WDX600D3S40
チップ Insert : WDXTO186012-G (ACP300)
切削条件 Cutting conditions : $v_c=150\text{m/min}$ $f=0.16\text{mm/rev}$ $H=60\text{mm}$ 貫通 Through Wet
従来工具切削条件 : $v_c=30\text{m/min}$ $f=0.20\text{mm/rev}$ $H=60\text{mm}$ 貫通 Through Wet

大径においても安定加工を実現!!
Stable drilling of even large-diameter holes.
従来工具に対して能率4倍!!
Four times more efficient than conventional tools.

SumiDrill WDX 型 正常摩耗 Normal wear

他社品 Competitor's Product 欠け Chipping

外刃 Outer insert 中心刃 Internal insert

被削材 Work material : プレート Steel plate (S50C)
使用工具 Tool : WDX200D3S25
チップ Insert : WDXTO63006-G (ACP100)
切削条件 Cutting conditions : $v_c=200\text{m/min}$ $f=0.12\text{mm/rev}$ $H=50\text{mm}$ 貫通 Through Wet
*サンプル写真は18m加工時点の結果。Above two pictures are result of 18m after cutting.

外刃、中心刃共に正常摩耗で高速領域でも安定加工可能。
適用困難のドリル中心刃にもCVD材種を適用することで更に経済性アップ。
Outer insert and internal insert of Sumi Drill WDX Type ACP100 shows normal wear and can cutting stable on high speed condition.

SumiDrill WDX 型 1400穴/コーナー 1,400 holes per corner

他社品 Competitor's Product 800穴/コーナー 800 holes per corner

寿命1.7倍!
Tool life is 1.7 times longer

加工穴数
No. of Holes

被削材 Work material : プレート Steel plate (S15C)
使用工具 Tool : WDX145D3S20 チップ Insert : WDXTO42004-L (ACP300)
切削条件 Cutting conditions : $v_c=205\text{m/min}$ $f=0.042\text{mm/rev}$ $H=15\text{mm}$ 貫通 Through Wet

内壁の状態も良好 (びびりなし)
Good internal condition (no chattering)

寿命が1.7倍と大幅に向上した。
Tool life has been extended 1.7 times longer than that of conventional types.
クランプ剛性小でも、加工面にびびり無く良好。
No chattering on drilled surface even with low clamp rigidity.

抜け際が傾斜面でも問題なし
No problems even if exit surface is angled.

被削材 Work material : プレート Steel plate (S15C)
使用工具 Tool : WDX430D3S40 チップ Insert : WDXTO125012-H (ACP300)
切削条件 Cutting conditions : $v_c=136\text{m/min}$ $f=0.15\text{mm/rev}$ $H=60+50\text{mm}$ (半円部 Semi-circular section) 貫通 Through Wet

不安定な加工状況(穴奥が断続切削)においても、安定加工が可能。
従来品に対して切削音も静か。
SumiDrill WDX Type can perform stable machining even under unstable machining condition (interrupted cutting at the hole end).
Cutting noise is quieter compared to conventional tools.

加工用途 Application	食いつきが斜めの場合 Angled Surface	半割り穴 Half Cylindrical	下穴ありの場合 Pre-cast Hole	交差穴 Intersecting Holes	ボーリング Boring	外径加工 External Turning	重ね板 Laminated Plates	バックボーリング Back Boring
送り量(f) mm/rev Feed Rate (f)	0.05	0.05	0.08	0.05	0.1	0.1	不可 Not applicable	不可 Not applicable

SumiDrill WDX 型 特型設計お問い合わせシート

SumiDrill WDX Type Inquiry sheet for special design

ご希望の特型形状を選択し、下表に寸法をご記入下さい。
Select the special shape you require and fill in the dimensions in the boxes below.

ご記入後は、最寄りの弊社営業所または取扱販売店までご連絡下さい。

その他の形状、寸法などのご要望がございましたらお気軽にお問い合わせ下さい。
After completing the form, contact your nearest Sumitomo Electric Hardmetal dealer or distributor.
Ask your dealer or distributor if you require shapes or dimensions that are not listed here.

貴社名 / ご連絡先 Company/Contact Information

■ ドリル形状 Drill Shape

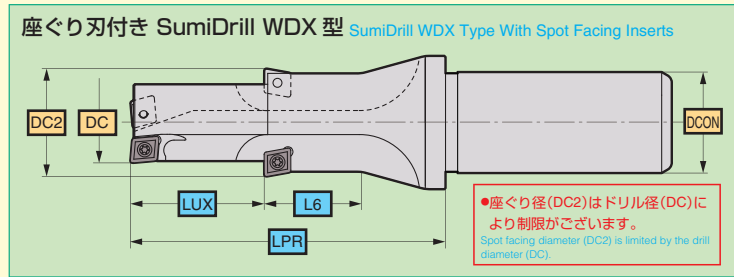
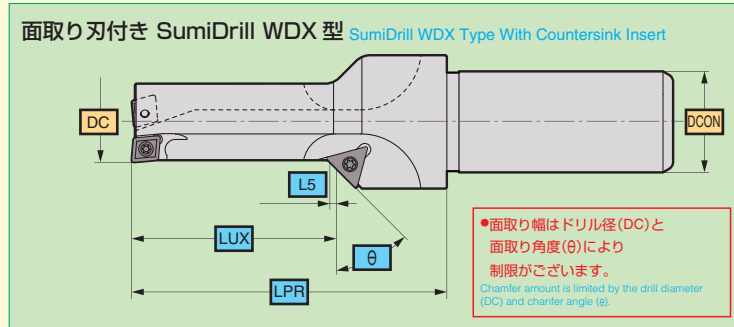
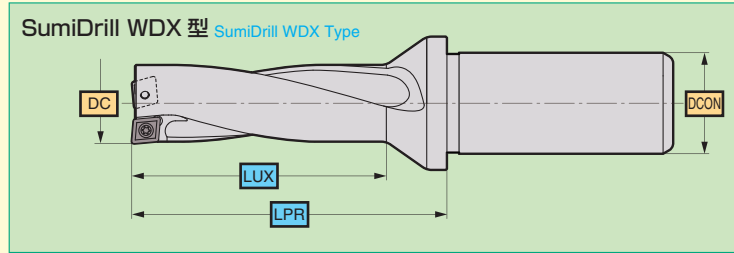

■ シャンク形状 Cutter Body

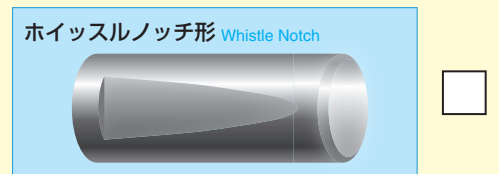
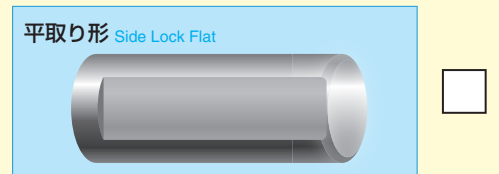
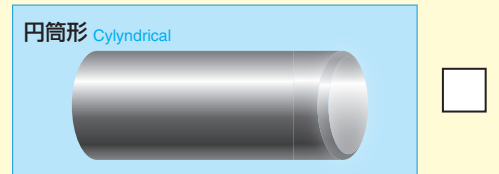

■ 対応チップ Compatible Inserts

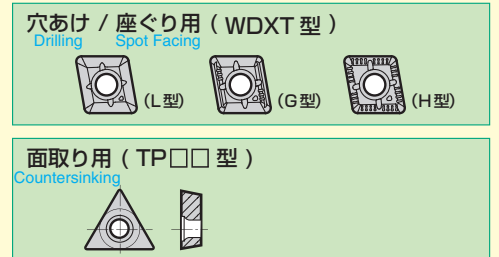

DC 【刃径 Diameter】	φ13~φ55mm	mm
DCON(※)【シャンク径 Shank Diameter】	φ20~φ40mm	mm
DC2 【座ぐり径 Spot Face Diameter】	DC+2~DC+20mm	mm
LUX 【ドリル深さ Drill Depth】	DC×4 以下	mm
LPR(※)【突出長さ Over hang】	200mm 以下	mm

L5 【面取り幅 Countersink Width】	3mm 以下	mm
LUX+L6【ドリル深さ+座ぐり深さ Drill Depth + Spot Face Depth】	DC×4 以下	mm
θ (※)【面取り角度 Countersink Angle】	15~60°	°

(※) 寸法には制限がございますので、ご留意下さい。 Dimensional restrictions apply.

その他のご要望 Other Requests



● 高温の切りくずが飛散したり長く伸びた切りくずが排出されることがありますので、安全カバーや保護メガネ等の保護具を使用し、防災・防火に十分ご注意ください。
● Very hot or lengthy chips may be discharged while the machine is in operation. Therefore, machine guards, safety goggles or other protective covers must be used. Fire safety precautions must also be considered.

◆安全にお使いいただくために◆

● 鋭い切れ刃を持っているため取扱いにご注意ください。
● 使用方法を誤ったり、使用条件が不適切な場合、工具破損、飛散を招きますので推奨条件の範囲内でご使用ください。
● Please handle with care as this product has sharp edges.
● Improper cutting conditions or mis-handling of the tool may result in breakages or projectiles. Therefore, please use the tool within its recommended conditions.

● 不水溶性の切削液をご使用になる場合は、自動消火装置を設置するなどの対策を講じて頂き、火災にくれぐれもご注意ください。
● When using non-water soluble cutting oil, precautions against fire must be taken and please ensure that a fire extinguisher is placed near the machine.

住友電気工業株式会社

ハードメタル事業部 〒664-0016 兵庫県伊丹市昆陽北1-1-1 TEL(072)772-4531
Sumitomo Electric Industries, Ltd. FAX(072)772-4595
Hardmetal Division
Global Marketing Department 1-1-1, Koyakita, Itami, Hyogo 664-0016, Japan TEL+81-(72)-772-4535 FAX+81-(72)-771-0088

直営営業部 東京営業グループ ☎(03)6406-2635 名古屋営業グループ ☎(052)589-3873* 大阪営業グループ ☎(06)6221-3600
流通販売部 東京市販グループ ☎(03)6406-2636 名古屋市販グループ ☎(052)589-3873* 大阪市販グループ ☎(06)6221-3700

住友電工ツールネット株式会社 製造元 住友電工ハードメタル株式会社
営業部 東京 ☎(03)6406-2814 中部 ☎(052)589-3840* 大阪 ☎(06)6221-3900

フリーダイヤル 110番
0120-159110
※営業所移転につき、2016年6月より所在地・電話番号・FAXが変更になりました。